

Compact hydraulic power pack type KA2 and KAW2

Product documentation



For short period operation and standby mode

Operating pressure p_{\max} : 700 bar

Geometric displacement V_{\max} : 7.9 cm³/rev

Usable volume $V_{\text{use max}}$: 9.05 l

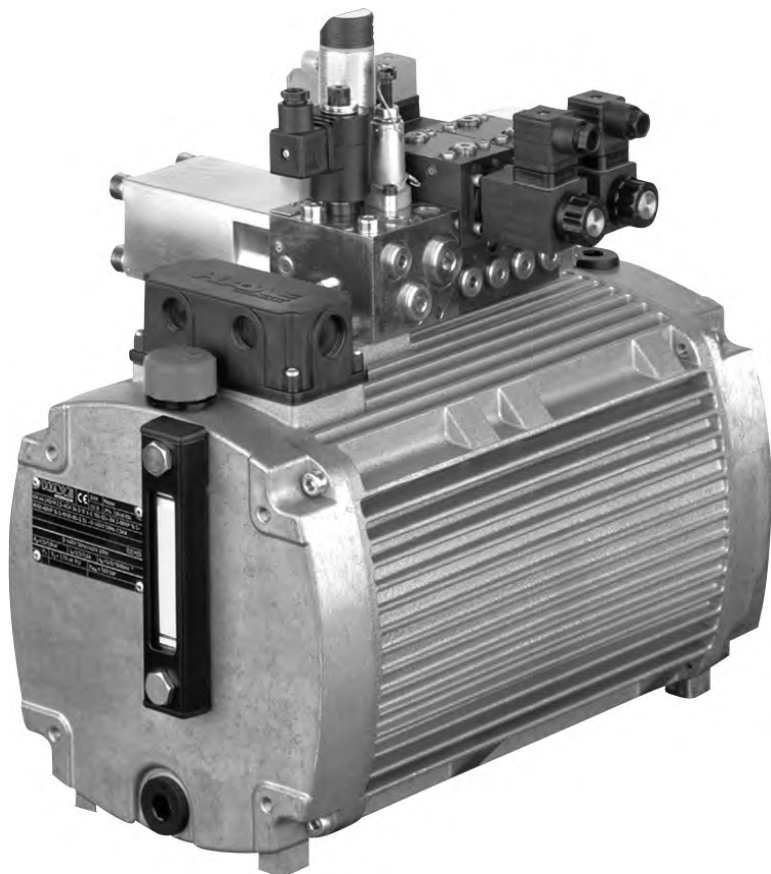

© by HAWE Hydraulik SE.

The reproduction and distribution of this document as well as the use and communication of its contents to others without explicit authorisation is prohibited.

Offenders will be held liable for the payment of damages.

All rights reserved in the event of patent or utility model applications.

Brand names, product names and trademarks are not specifically indicated. In particular with regard to registered and protected names and trademarks, usage is subject to legal provisions.

HAWE Hydraulik respects these legal provisions in all cases.

Printing date / document generated on: 01.02.2018

Contents

1	Overview compact hydraulic power pack type KA2 and KAW2.....	4
2	Available versions, main data.....	5
2.1	Motor and container.....	5
2.2	Pump.....	12
2.2.1	Single-circuit pumps.....	12
2.2.2	Dual-circuit pump with shared pedestal.....	26
3	Parameters.....	28
3.1	General.....	28
3.2	Electrical.....	31
4	Dimensions.....	39
4.1	Mounting hole pattern.....	39
4.2	Basic pump.....	40
4.3	Electrical and hydraulic connections.....	47
5	Assembly, operation and maintenance recommendations.....	52
5.1	Intended use.....	52
5.2	Assembly information.....	52
5.2.1	Transport information.....	53
5.2.2	Identification.....	53
5.2.3	Setting up and attaching.....	54
5.2.4	Electrical connection and selection of the motor protection circuit-breaker.....	55
5.2.5	Information on ensuring EMC (electromagnetic compatibility).....	55
5.3	Operating instructions.....	56
5.4	Maintenance information.....	59
5.5	Disposal information.....	60
6	Other information.....	61
6.1	Planning information.....	61
6.1.1	Selection advice.....	61
6.2	Explanations.....	69

Compact hydraulic power packs are a type of hydraulic power pack. They are characterised by a highly compact design, since the motor shaft of the electric motor also acts as the pump shaft.

Features and benefits:

- Additional separately driven fan for maximum utilisation of power
- Fill/usable volumes can be flexibly extended by modular tank extensions
- Long lifetime and excellent reliability achieved by using radial piston pumps
- Low oil fill volumes make it environmentally sound thanks to small cost of disposal and low costs for hydraulic fluid
- Co-ordinated range of valves and accessories from modular system
- Suitable for vertical and horizontal installation
- Optimum efficiency thanks to suboil motor cooling, direct transmission of force and cleverly designed heat dissipation

Intended applications:

- Brake and rotor adjustment modules on wind turbines
- Clamping systems on machine tools and appliances
- Hydraulic torque wrenches
- Rivets and clinching equipment
- Presses
- Handling systems



Compact hydraulic power pack type KA2 and KAW2

2 Available versions, main data

2.1 Motor and container

Order coding example:

KA 24	1	S	KS	E/	H 1,81	- A1/280	- FSR-24V	- 3x400 V 50 Hz		
KA 28	22	L1	KTF	P/	HZ 0,59/8,8	- ...		- 3x400 V 50 Hz	/24 V DC	- G 1/2 x 300

										Oil drain hose	Table 1g Oil drain hose
										Motor voltage for additional fans	Table 1d Motor voltage for additional fans
								Motor voltage	Table 5 Motor voltage		
							External side fan	Table 1f External side fan			
					Pump version	Pump version, see Chapter 2.2, "Pump"					
					Electrical connection	Table 1e Electrical connection					
					Additional options	Table 1d Additional options					
					Installation position	Table 1c Installation position					
					Tank size	Table 1b Tank size					
					Basic type and motor power	Table 1a Basic type and motor power					

Table 1a Basic type and motor power

Basic type	Motor voltages and motor data **			
		Nominal voltage **	Nominal power (kW)	Rated speed [rpm]
KA 21	3-phase motor	3x400 V 50 Hz	0.55	2790 (50 Hz)
		3x460 V 60 Hz	0.66	3350 (60 Hz)
KA 22	3-phase motor	3x400 V 50 Hz	1.1	2790 (50 Hz)
		3x460 V 60 Hz	1.32	3400 (60 Hz)
KA 23	3-phase motor	3x400 V 50 Hz	0.37	1360 (50 Hz)
		3x460 V 60 Hz	0.44	1650 (60 Hz)
KA 24	3-phase motor	3x400 V 50 Hz	0.75	1360 (50 Hz)
		3x460 V 60 Hz	0.9	1650 (60 Hz)
KA 26 * KA 26 V *	3-phase motor	3x400 V 50 Hz	1.4	2810 (50 Hz)
		3x460 V 60 Hz	1.68	3340 (60 Hz)
KA 28 *	3-phase motor	3x400 V 50 Hz	1.2	1380 (50 Hz)
		3x460 V 60 Hz	1.45	1680 (60 Hz)
KA 29 * KA 29 V *	3-phase motor	3x400 V 50 Hz	1.6	1390 (50 Hz)
		3x460 V 60 Hz	1.92	1690 (60 Hz)
KAW 21	Single-phase-motor	1x230 V 50 Hz	0.37	2770 (50 Hz)
		1x110 V 60 Hz		3340 (60 Hz)
KAW 22	Single-phase-motor	1x230 V 50 Hz	0.75	2810 (50 Hz)
		1x110 V 60 Hz		3400 (60 Hz)
KAW 23	Single-phase-motor	1x230 V 50 Hz	0.25	1380 (50 Hz)
		1x110 V 60 Hz		1650 (60 Hz)
KAW 24	Single-phase-motor	1x230 V 50 Hz	0.50	1390 (50 Hz)
		1x110 V 60 Hz		1680 (60 Hz)
KAW 26 *	Single-phase-motor	1x230 V 50 Hz	1.10	2770 (50 Hz)
		1x110 V 60 Hz		3340 (60 Hz)
KAW 28 *	Single-phase-motor	1x230 V 50 Hz	0.7	1370 (50 Hz)
		1x110 V 60 Hz		1650 (60 Hz)

Note

The actual power consumption depends on the load and can be up to 1.8 x nominal power.

- * Marked basic types only in connection with tank sizes 1, 11, 2, 21, 22, 3 in accordance with Table 1b
- ** Other available nominal voltages, see [Chapter 3.2, "Electrical"](#) Table 5 and [Chapter 6.1, "Planning information"](#)
- basic types KA ... V (encased stator) for hydraulic installations with water content (such as a coolant) of up to 0.3 %

Table 1b Tank size

Tank size	Combination	Fill volume V_{fill} (l)	Usable volume vertical V_{usable} (l)	Usable volume horizontal V_{usable} (l)
No designation		3.9	1.85	1.5
1		5.0	2.7	2.0
01		5.0	1.85	2.0
11		6.1	2.7	2.5
2		7.5	5.45	3.15
02		7.5	--	3.15
21		8.6	5.45	3.65
22		11.1	--	4.8
3		11.1	9.05	4.8

1 Pedestal, valve mounting, terminal box, additional options

i Note

- The fill volume and usable volume may deviate slightly from the values indicated here, depending on the motor and pump.

Table 1c Installation position

Vertical

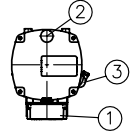
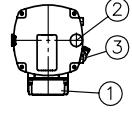
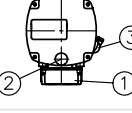
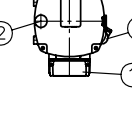
Coding	Comment	Installation position
S	Series	
S1	Lid rotated through 90° on the top	
S14	Lid rotated through 90° on the top and bottom	
S25	Lid rotated through 180° on the top and bottom	
S36	Lid rotated through 270° on the top and bottom	

Horizontal

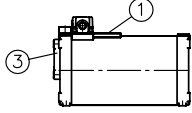
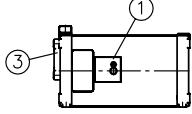
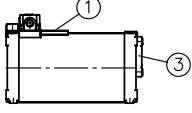
Coding	Comment	Installation position
L	Series	
L1	Pedestal rotated through 90°	
L4	Type plate and level gauge on the "back"	
L14	Combination of L1 and L4	

- 1 Pedestal, valve mounting, terminal box, additional options
- 2 Oil filler, breather filter
- 3 Level gauge

i Note

- The horizontal version can be incorporated vertically.
- The vertical version within radial piston design (coding H, HH and HZ in accordance with [Chapter 2.2, "Pump"](#)) cannot be inserted horizontally.
- Re. 1: Setup of a connection block/directional valve bank, see [Chapter 6.1, "Planning information"](#) ("Selection of connection blocks" and "Selection of directional valve banks")

Table 1d Additional options

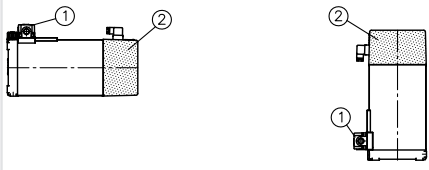
Coding	Comment	Vertical	Horizontal
No designation	Without additional equipment	●	●
K	Oil level gauge / level gauge right	●	●
K1	Oil level gauge / level gauge left	●	-
KK	Oil level gauge / level gauge right, in any extension, only with extension coding 3	●	-
KK1	Oil level gauge / level gauge left, in any extension, only with extension coding 3	●	-
KS, K1S	Level gauge with a level switch (N/O contact), switching function for a falling level	●	-
KD, K1D	Level gauge with a level switch (N/C contact), switching function for a falling level	●	-
KDD, KSS	2-point level switch (switch-off/prewarning), combination of two N/C contacts (DD) and two N/O contacts (SS)	●	-
S	Level switch (N/O contact)	-	●
D	Level switch (N/C contact)	-	●
DD, SS	2-point level switch (switch-off/prewarning), combination of two N/C contacts (DD) and two N/O contacts (SS), not with KAW-type, not in combination with a T-coding temperature switch	-	●
T	Temperature switch (switching point of 80°C), series in the KAW model	●	●
T60	Temperature switch (switching point of 60°C), only in the KA model	●	●
TT60, TT50	2-point temperature switch (switching point of 80°C / 60°C or 50°C, switch-off/prewarning); in horizontal version, not in combination with an S or D-coding level switch	●	●
G	Silica gel filter (instead of the breather filter, see Chapter 6.1.1, "Selection advice" ("Silica gel filter")), cannot be retrofitted, not with an additional fan with coding F	●	-
F	Additional fan (see Chapter 6.1.1, "Selection advice" ("Determination of excess temperature")), available motor voltages and other motor data, see Chapter 3.2, "Electrical" , can be retrofitted, not in combination with installation position L, L1 or L4 and oil level gauge / level gauge, coding K.  <p>1 Pedestal, valve mounting, terminal box, additional option 2 Additional fan</p>	●	●

Re. Table 1d Additional options

Coding	Comment	Vertical	Horizontal
F1	<p>Additional fan same as coding F, but assembled in the opposite position, not in combination with installation position L or L1 and oil level gauge / level gauge, coding K.</p>  <p>1 Pedestal, valve mounting, terminal box, additional option 2 Additional fan</p>	-	●
B	<ul style="list-style-type: none"> ▪ Filler reduction, no need for a dipstick ▪ Filler sieve mesh width 0.63 mm ▪ Vertical version: not in combination with the additional fan, coding F ▪ Cannot be retrofitted 	●	●
B1	<ul style="list-style-type: none"> ▪ Filler reduction, no need for a dipstick ▪ Filler sieve mesh width 0.63 mm ▪ Cannot be retrofitted ▪ Where necessary, watch out for a collision with the mounted valve bank! 	-	●

Table 1e Electrical connection

Coding	Comment
No designation	Series (terminal box)
P	HARTING plug
PM, PM1, PM2	HARTING plug with an additional connection M12x1 right, left or on both sides for temperature and/or level switch (horizontal version), in a vertical version and level switch (coding KD, KS) M12 connection to the level gauge Coding PM2 not in combination with suppressor coding PE
M, M1, M2	Terminal box with an additional connection M12x1 right, left or on both sides for temperature and/or level switch (horizontal version), in a vertical version and level switch (coding KD, KS) M12 connection to the level gauge Coding M2 not in combination with suppressor coding E or filler reduction coding B
E, PE	Additional suppressor on terminal box or HARTING plug, see Chapter 3.2, "Electrical" , only with the KA-type

Table 1f External side fan

Coding	Comment	Vertical	Horizontal
FSL	External side fan left (see Chapter 6.1.1, "Selection advice" ("Determination of excess temperature")), available motor voltages and other motor data, see Chapter 3.2, "Electrical" , can be retrofitted	● (not K1)	●
FSR	External side fan right (see Chapter 6.1.1, "Selection advice" ("Determination of excess temperature")), available motor voltages and other motor data, see Chapter 3.2, "Electrical" , can be retrofitted	● (not K)	● (not L1)
FSH	External side fan rear (see Chapter 6.1.1, "Selection advice" ("Determination of excess temperature")), available motor voltages and other motor data, see Chapter 3.2, "Electrical" , can be retrofitted	●	-
FSLR	2 external side fans right and left (see Chapter 6.1.1, "Selection advice" ("Determination of excess temperature")), available motor voltages and other motor data, see Chapter 3.2, "Electrical" , can be retrofitted	● (not K(1))	● (not L1)
	<p>Options:</p> <ul style="list-style-type: none"> ▪ No details - no safety guard ▪ "S" - Safety guard <p>Motor voltage details:</p> <ul style="list-style-type: none"> ▪ " -1x110 V " (1x115 V 50 Hz, 1x110 V 60 Hz ⊥) ▪ " -1x230 V " (1x230 V 50/60 Hz ⊥) ▪ " -24 V " (24 V DC) <p>Details of the plug on the opposite side:</p> <ul style="list-style-type: none"> ▪ No details - no opposite plug ▪ CA3TY1 - opposite plug with a 3m cable for a motor voltage of 1x110 V, 1x230 V ▪ CA3TY2 - opposite plug with a 3m cable for a motor voltage of 24 VDC 		

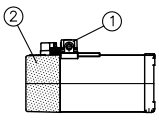
Table 1g Oil drain hose

Coding	Description
No designation	Tapped plug G 1/2 (BSPP)
G 1/2 x 300	Oil drain hose approximately 300 mm with a ball valve
G 1/2 x 500	Oil drain hose approximately 500 mm with a ball valve
G 1/2 W x 300	Oil drain hose approximately 300 mm with a bracket and ball valve
G 1/2 W x 500	Oil drain hose approximately 500 mm with a bracket and ball valve

2.2 Pump

2.2.1 Single-circuit pumps

Order coding example:

KA 242 DT/1 - H 6,7 - A1/180 - 3x400 V 50 Hz

Single-circuit pump with a 3-phase motor Table 2a Single-circuit pump with a 3-phase motor

Table 2a Single-circuit pump (radial piston pump) with a 3-phase motor

Note

- The delivery flow Q_{\max} relates to the rated speed and varies depending on the load (see diagrams [Chapter 3.2, "Electrical"](#)).
- Notes on the pressures p_{\max} (see [Chapter 3.2, "Electrical"](#), Table 5).
- In pump version **Z**, the max. hydraulic work value $(pV_g)_{\max}$ is to be reduced by 10%.
- **The permissible pressures p_{\max} relate to a version with a 3x400/230 V 50 Hz or 3x460 V 60 Hz motor.**
- Be aware of different motor power ratings and resulting permissible maximum pressures $p_{\max} = (pV_g)_{\max}/V_g$ at other nominal voltages and power frequencies, $(pV_g)_{\max}$ (see [Chapter 3.2, "Electrical"](#), Table 5)"

Radial piston pump H

Delivery flow coding		H 0.33	H 0.47	H 0.59	H 0.66	H 0.91	H 0.93	
Piston diameter (mm)		4	5	4	6	7	5	
Number of pump elements		3	3	6	3	3	6	
Displacement volume V_g (cm ³ /rev)		0.23	0.35	0.45	0.51	0.69	0.71	
KA 21	Permissible pressure p_{max} (bar)	700	465	360	320	235	230	
	Delivery flow Q_{max} (lpm)	50 Hz	0.63	0.99	1.26	1.42	1.93	1.97
		60 Hz	0.76	1.18	1.52	1.70	2.32	2.37
KA 22	Permissible pressure p_{max} (bar)	700	700	700	700	700	700	
	Delivery flow Q_{max} (lpm)	50 Hz	0.63	0.99	1.26	1.42	1.93	1.97
		60 Hz	0.76	1.18	1.52	1.70	2.32	2.37
KA 23	Permissible pressure p_{max} (bar)	700	620	485	430	315	310	
	Delivery flow Q_{max} (lpm)	50 Hz	0.31	0.48	0.62	0.69	0.94	0.96
		60 Hz	0.37	0.58	0.75	0.84	1.14	1.17
KA 24	Permissible pressure p_{max} (bar)	700	700	700	700	700	700	
	Delivery flow Q_{max} (lpm)	50 Hz	0.31	0.48	0.62	0.69	0.94	0.96
		60 Hz	0.37	0.58	0.75	0.84	1.14	1.17
KA 26 KA 26 V	Permissible pressure p_{max} (bar)	700	700	700	700	700	700	
	Delivery flow Q_{max} (lpm)	50 Hz	0.63	0.99	1.26	1.42	1.93	1.97
		60 Hz	0.76	1.18	1.52	1.70	2.32	2.37
KA 28	Permissible pressure p_{max} (bar)	700	700	700	700	700	700	
	Delivery flow Q_{max} (lpm)	50 Hz	0.31	0.48	0.62	0.69	0.94	0.96
		60 Hz	0.37	0.58	0.75	0.84	1.14	1.17
KA 29 KA 29 V	Permissible pressure p_{max} (bar)	700	700	700	700	700	700	
	Delivery flow Q_{max} (lpm)	50 Hz	0.31	0.48	0.62	0.69	0.94	0.96
		60 Hz	0.37	0.58	0.75	0.84	1.14	1.17

Radial piston pump H

Delivery flow coding		H 1.18	H 1.33	H 1.51	H 1.81	H 2.36	H 2.99	
Piston diameter (mm)		8	6	9	7	8	9	
Number of pump elements		3	6	3	6	6	6	
Displacement volume V_g (cm ³ /rev)		0.91	1.02	1.15	1.39	1.81	2.29	
KA 21	Permissible pressure p_{max} (bar)	180	160	140	115	90	70	
	Delivery flow Q_{max} (lpm)	50 Hz	2.52	2.84	3.19	3.87	5.05	6.39
		60 Hz	3.03	3.41	3.84	4.64	6.06	7.67
KA 22	Permissible pressure p_{max} (bar)	570	510	450	370	285	225	
	Delivery flow Q_{max} (lpm)	50 Hz	2.52	2.84	3.19	3.87	5.05	6.39
		60 Hz	3.03	3.41	3.84	4.64	6.06	7.67
KA 23	Permissible pressure p_{max} (bar)	240	215	190	155	120	95	
	Delivery flow Q_{max} (lpm)	50 Hz	1.23	1.38	1.56	1.88	2.46	3.11
		60 Hz	1.49	1.68	1.89	2.29	2.99	3.78
KA 24	Permissible pressure p_{max} (bar)	650	580	510	425	325	255	
	Delivery flow Q_{max} (lpm)	50 Hz	1.23	1.38	1.56	1.88	2.46	3.11
		60 Hz	1.49	1.68	1.89	2.29	2.99	3.78
KA 26 KA 26 V	Permissible pressure p_{max} (bar)	640	575	510	420	320	255	
	Delivery flow Q_{max} (lpm)	50 Hz	2.52	2.84	3.19	3.87	5.05	6.39
		60 Hz	3.03	3.41	3.84	4.64	6.06	7.67
KA 28	Permissible pressure p_{max} (bar)	700	700	550	625	480	375	
	Delivery flow Q_{max} (lpm)	50 Hz	1.23	1.38	1.56	1.88	2.46	3.11
		60 Hz	1.49	1.68	1.89	2.29	2.99	3.78
KA 29 KA 29 V	Permissible pressure p_{max} (bar)	700	700	550	700	690	545	
	Delivery flow Q_{max} (lpm)	50 Hz	1.23	1.38	1.56	1.88	2.46	3.11
		60 Hz	1.49	1.68	1.89	2.29	2.99	3.78

Radial piston pump H



Note

- Version with PE-type pump elements in accordance with [D 5600](#)
- only available in a vertical version (Table 1c)

Delivery flow coding	H 1.84	H 2.66	H 3.12	H 3.61	H 3.69	H 4.14
Piston diameter (mm)	10	12	13	14	10	15
Number of pump elements	3	3	3	3	6	3
Displacement volume V_g (cm ³ /rev)	1.41	2.04	2.39	2.77	2.83	3.18

KA 21	Permissible pressure p_{max}	(bar)		115	80	65	55	55	50
	Delivery flow Q_{max}	(lpm)	50 Hz	3.90	5.65	6.62	7.67	7.84	8.81
			60 Hz	4.69	6.79	7.96	9.22	9.42	10.59
KA 22	Permissible pressure p_{max}	(bar)		365	250	215	185	180	160
	Delivery flow Q_{max}	(lpm)	50 Hz	3.90	5.65	6.62	7.67	7.84	8.81
			60 Hz	4.69	6.79	7.96	9.22	9.42	10.59
KA 23	Permissible pressure p_{max}	(bar)		155	105	90	75	75	65
	Delivery flow Q_{max}	(lpm)	50 Hz	1.91	2.76	3.23	3.74	3.83	4.30
			60 Hz	2.31	3.34	3.91	4.54	4.63	5.21
KA 24	Permissible pressure p_{max}	(bar)		415	285	245	210	205	185
	Delivery flow Q_{max}	(lpm)	50 Hz	1.91	2.76	3.23	3.74	3.83	4.30
			60 Hz	2.31	3.34	3.91	4.54	4.63	5.21
KA 26 KA 26 V	Permissible pressure p_{max}	(bar)		410	285	240	210	205	180
	Delivery flow Q_{max}	(lpm)	50 Hz	3.90	5.65	6.62	7.67	7.84	8.81
			60 Hz	4.69	6.79	7.96	9.22	9.42	10.59
KA 28	Permissible pressure p_{max}	(bar)		560	390	330	290	305	250
	Delivery flow Q_{max}	(lpm)	50 Hz	1.91	2.76	3.23	3.74	3.83	4.30
			60 Hz	2.31	3.34	3.91	4.54	4.63	5.21
KA 29 KA 29 V	Permissible pressure p_{max}	(bar)		560	390	330	290	440	250
	Delivery flow Q_{max}	(lpm)	50 Hz	1.91	2.76	3.23	3.74	3.83	4.30
			60 Hz	2.31	3.34	3.91	4.54	4.63	5.21

Radial piston pump H



Note

- Version with PE-type pump elements in accordance with [D 5600](#)
- only available in a vertical version (Table 1c)

Delivery flow coding		H 4.72	H 5.31	H 6.24	H 7.23	H 8.29	H 9.45
Piston diameter (mm)		16	12	13	14	15	16
Number of pump elements		3	6	6	6	6	6
Displacement volume V_g (cm ³ /rev)		3.62	4.07	4.78	5.54	6.36	7.24
KA 21	Permissible pressure p_{max} (bar)	45					
	Delivery flow Q_{max} (lpm)						
KA 22	Permissible pressure p_{max} (bar)	140					
	Delivery flow Q_{max} (lpm)						
KA 23	Permissible pressure p_{max} (bar)	60	50	45	35	30	30
	Delivery flow Q_{max} (lpm)						
KA 24	Permissible pressure p_{max} (bar)	160	140	120	105	90	80
	Delivery flow Q_{max} (lpm)						
KA 26 KA 26 V	Permissible pressure p_{max} (bar)	160					
	Delivery flow Q_{max} (lpm)						
KA 28	Permissible pressure p_{max} (bar)	220	210	180	155	135	120
	Delivery flow Q_{max} (lpm)						
KA 29 KA 29 V	Permissible pressure p_{max} (bar)	220	305	260	225	195	170
	Delivery flow Q_{max} (lpm)						

Gear pump Z

Delivery flow coding		Z 1.1	Z 1.7	Z 2.0	Z 2.7	Z 3.5	Z 4.5	
Size		1	1	1	1	1	1	
Displacement volume V_g (cm ³ /rev)		0.86	1.26	1.69	2.09	2.51	3.32	
KA 21	Permissible pressure p_{max} (bar)	155	110	80	65	55	40	
	Delivery flow Q_{max} (lpm)	50 Hz	2.23	3.07	3.91	5.30	6.70	8.65
		60 Hz	2.68	3.69	4.69	6.37	8.04	10.39
KA 22	Permissible pressure p_{max} (bar)	200	200	200	200	185	140	
	Delivery flow Q_{max} (lpm)	50 Hz	2.23	3.07	3.91	5.30	6.70	8.65
		60 Hz	2.68	3.69	4.69	6.37	8.04	10.39
KA 23	Permissible pressure p_{max} (bar)	200	145	110	90	75	55	
	Delivery flow Q_{max} (lpm)	50 Hz	1.09	1.50	1.90	2.58	3.26	4.22
		60 Hz	1.32	1.82	2.31	3.14	3.96	5.12
KA 24	Permissible pressure p_{max} (bar)	200	200	200	200	200	160	
	Delivery flow Q_{max} (lpm)	50 Hz	1.09	1.50	1.90	2.58	3.26	4.22
		60 Hz	1.32	1.82	2.31	3.14	3.96	5.12
KA 26 KA 26 V	Permissible pressure p_{max} (bar)	200	200	200	200	200	155	
	Delivery flow Q_{max} (lpm)	50 Hz	2.23	3.07	3.91	5.30	6.70	8.65
		60 Hz	2.68	3.69	4.69	6.37	8.04	10.39
KA 28	Permissible pressure p_{max} (bar)	200	200	200	200	200	200	
	Delivery flow Q_{max} (lpm)	50 Hz	1.09	1.50	1.90	2.58	3.26	4.22
		60 Hz	1.32	1.82	2.31	3.14	3.96	5.12
KA 29 KA 29 V	Permissible pressure p_{max} (bar)	200	200	200	200	200	200	
	Delivery flow Q_{max} (lpm)	50 Hz	1.09	1.50	1.90	2.58	3.26	4.22
		60 Hz	1.32	1.82	2.31	3.14	3.96	5.12

Gear pump Z

Delivery flow coding		Z 5.2	Z 6.4	Z 6.9	Z 8.8	Z 9.8	Z 11.3	
Size		1	1	1	1	1	1	
Displacement volume V_g (cm ³ /rev)		3.61	4.39	4.79	6.21	7.01	7.89	
KA 21	Permissible pressure p_{max} (bar)	40	30	30				
	Delivery flow Q_{max} (lpm)	50 Hz	10.04	12.28	13.39			
		60 Hz	12.06	14.74	16.08			
KA 22	Permissible pressure p_{max} (bar)	125	105	95	75	65	55	
	Delivery flow Q_{max} (lpm)	50 Hz	10.04	12.28	13.39	17.02	19.53	22.04
		60 Hz	12.06	14.74	16.08	20.44	23.45	
KA 23	Permissible pressure p_{max} (bar)	50	45	40	30			
	Delivery flow Q_{max} (lpm)	50 Hz	4.90	5.98	6.53	8.30		
		60 Hz	5.94	7.26	7.92	10.07		
KA 24	Permissible pressure p_{max} (bar)	145	120	110	85	75	65	
	Delivery flow Q_{max} (lpm)	50 Hz	4.90	5.98	6.53	8.30	9.52	10.74
		60 Hz	5.94	7.26	7.92	10.07	11.55	13.04
KA 26 KA 26 V	Permissible pressure p_{max} (bar)	145	115	105	80	75	65	
	Delivery flow Q_{max} (lpm)	50 Hz	10.04	12.28	13.39	17.02	19.53	22.04
		60 Hz	12.06	14.74	16.08	20.44	23.45	
KA 28	Permissible pressure p_{max} (bar)	200	175	160	125	110	95	
	Delivery flow Q_{max} (lpm)	50 Hz	4.90	5.98	6.53	8.30	9.52	10.74
		60 Hz	5.94	7.26	7.92	10.07	11.55	13.04
KA 29 KA 29 V	Permissible pressure p_{max} (bar)	200	200	200	180	160	140	
	Delivery flow Q_{max} (lpm)	50 Hz	4.90	5.98	6.53	8.30	9.52	10.74
		60 Hz	5.94	7.26	7.92	10.07	11.55	13.04

Order coding example:

KAW 26/1P1 - **Z 4,5** - AL11E/120 - 1x230 V 50 Hz

Single-circuit pump with a single-phase motor Table 2b Single-circuit pump with a single-phase motor

Table 2b Single-circuit pump (radial piston pump H or gear pump Z) with a single-phase motor

Note

- The delivery flow Q_{\max} relates to the rated speed and varies depending on the load (see diagrams [Chapter 3.2, "Electrical"](#)).
- Notes on the pressures p_{\max} (see [Chapter 3.2, "Electrical"](#), Table 5).
- In pump version **Z**, the max. hydraulic work value $(pV_g)_{\max}$ is to be reduced by 10%.
- **The permissible pressures p_{\max} relate to a version with a 1x230 V 50 Hz .**
- Be aware of different motor power ratings and resulting permissible maximum pressures $p_{\max} = (pV_g)_{\max}/V_g$ at other nominal voltages and power frequencies, $(pV_g)_{\max}$ (see [Chapter 3.2, "Electrical"](#), Table 5)"
- The version with a single-phase motor requires an operating capacitor. For recommendations and selection advice, see [Chapter 3.2, "Electrical"](#) and [Chapter 6.1, "Planning information"](#) ("Selection of the operating capacitor for type KAW"). It is not included in the scope of delivery.
- It cannot be started up directly against the effects of pressure!

Radial piston pump H



Note

- At a power frequency of 60 Hz, the delivery flow is approximately 1.2 times higher than that indicated here
- Be aware of different motor power ratings and resulting permissible maximum pressures $p_{\max} = (pV_g)_{\max}/V_g$ at other nominal voltages and power frequencies, $(pV_g)_{\max}$ (see [Chapter 3.2, "Electrical", Table 5](#))"

Delivery flow coding	H 0.33	H 0.47	H 0.59	H 0.66	H 0.91	H 0.93
Piston diameter (mm)	4	5	4	6	7	5
Number of pump elements	3	3	6	3	3	6
Displacement volume V_g (cm ³ /rev)	0.23	0.35	0.45	0.51	0.69	0.71

KAW 21	Permissible pressure p_{\max} (bar)		435	285	220	195	145	140
	Delivery flow Q_{\max} (lpm) 50 Hz		0.63	0.99	1.26	1.42	1.93	1.97
KAW 22	Permissible pressure p_{\max} (bar)		700	655	510	450	330	320
	Delivery flow Q_{\max} (lpm) 50 Hz		0.63	0.99	1.26	1.42	1.93	1.97
KAW 23	Permissible pressure p_{\max} (bar)		630	410	320	285	210	200
	Delivery flow Q_{\max} (lpm) 50 Hz		0.31	0.48	0.62	0.69	0.94	0.96
KAW 24	Permissible pressure p_{\max} (bar)		700	700	700	685	505	490
	Delivery flow Q_{\max} (lpm) 50 Hz		0.31	0.48	0.62	0.69	0.94	0.96
KAW 26	Permissible pressure p_{\max} (bar)		700	700	610	540	395	385
	Delivery flow Q_{\max} (lpm) 50 Hz		0.63	0.99	1.26	1.42	1.93	1.97
KAW 28	Permissible pressure p_{\max} (bar)		700	700	700	700	580	560
	Delivery flow Q_{\max} (lpm) 50 Hz		0.31	0.48	0.62	0.69	0.94	0.96

Radial piston pump H



Note

- At a power frequency of 60 Hz, the delivery flow is approximately 1.2 times higher than that indicated here
- Be aware of different motor power ratings and resulting permissible maximum pressures $p_{\max} = (pV_g)_{\max}/V_g$ at other nominal voltages and power frequencies, $(pV_g)_{\max}$ (see [Chapter 3.2, "Electrical", Table 5](#))"

Delivery flow coding	H 1.18	H 1.33	H 1.51	H 1.81	H 2.36	H 2.99
Piston diameter (mm)	8	6	9	7	8	9
Number of pump elements	3	6	3	6	6	6
Displacement volume V_g (cm ³ /rev)	0.91	1.02	1.15	1.39	1.81	2.29

KAW 21	Permissible pressure p_{\max} (bar)		110	95	85	70	55	40
	Delivery flow Q_{\max} (lpm) 50 Hz		2.52	2.84	3.19	3.87	5.05	6.39
KAW 22	Permissible pressure p_{\max} (bar)		250	225	200	165	125	100
	Delivery flow Q_{\max} (lpm) 50 Hz		2.52	2.84	3.19	3.87	5.05	6.39
KAW 23	Permissible pressure p_{\max} (bar)		160	140	125	105	80	60
	Delivery flow Q_{\max} (lpm) 50 Hz		1.23	1.38	1.56	1.88	2.46	3.11
KAW 24	Permissible pressure p_{\max} (bar)		385	340	305	250	190	150
	Delivery flow Q_{\max} (lpm) 50 Hz		1.23	1.38	1.56	1.88	2.46	3.11
KAW 26	Permissible pressure p_{\max} (bar)		300	270	240	195	150	120
	Delivery flow Q_{\max} (lpm) 50 Hz		2.52	2.84	3.19	3.87	5.05	6.39
KAW 28	Permissible pressure p_{\max} (bar)		440	390	345	285	220	175
	Delivery flow Q_{\max} (lpm) 50 Hz		1.23	1.38	1.56	1.88	2.46	3.11

Radial piston pump H

i Note

- Version with PE-type pump elements in accordance with [D 5600](#)
- only available in a vertical version (Table 1c)
- At a power frequency of 60 Hz, the delivery flow is approximately 1.2 times higher than that indicated here
- Be aware of different motor power ratings and resulting permissible maximum pressures $p_{\max} = (pV_g)_{\max}/V_g$ at other nominal voltages and power frequencies, $(pV_g)_{\max}$ (see [Chapter 3.2, "Electrical", Table 5](#))"

Delivery flow coding	H 1.84	H 2.66	H 3.12	H 3.61	H 3.69	H 4.14
Piston diameter (mm)	10	12	13	14	10	15
Number of pump elements	3	3	3	3	6	3
Displacement volume V_g (cm ³ /rev)	1.41	2.04	2.39	2.77	2.83	3.18

KAW 21	Permissible pressure p_{\max} (bar)		70	45	40	35	35	30
	Delivery flow Q_{\max} (lpm) 50 Hz		3.86	5.59	6.55	7.59	7.75	8.71
KAW 22	Permissible pressure p_{\max} (bar)		160	110	95	80	80	70
	Delivery flow Q_{\max} (lpm) 50 Hz		3.86	5.59	6.55	7.59	7.75	8.71
KAW 23	Permissible pressure p_{\max} (bar)		100	70	60	50	50	45
	Delivery flow Q_{\max} (lpm) 50 Hz		1.90	2.75	3.22	3.73	3.81	4.29
KAW 24	Permissible pressure p_{\max} (bar)		245	170	145	125	120	110
	Delivery flow Q_{\max} (lpm) 50 Hz		1.90	2.75	3.22	3.73	3.81	4.29
KAW 26	Permissible pressure p_{\max} (bar)		195	130	115	95	95	85
	Delivery flow Q_{\max} (lpm) 50 Hz		3.86	5.59	6.55	7.59	7.75	8.71
KAW 28	Permissible pressure p_{\max} (bar)		280	195	165	140	140	125
	Delivery flow Q_{\max} (lpm) 50 Hz		1.90	2.75	3.22	3.73	3.81	4.29

Radial piston pump H



Note

- Version with PE-type pump elements in accordance with [D 5600](#)
- only available in a vertical version (Table 1c)
- At a power frequency of 60 Hz, the delivery flow is approximately 1.2 times higher than that indicated here
- Be aware of different motor power ratings and resulting permissible maximum pressures $p_{\max} = (pV_g)_{\max}/V_g$ at other nominal voltages and power frequencies, $(pV_g)_{\max}$ (see [Chapter 3.2, "Electrical", Table 5](#))"

Delivery flow coding	H 4.72	H 5.31	H 6.24	H 7.23	H 8.29	H 9.45
Piston diameter (mm)	16	12	13	14	15	16
Number of pump elements	3	6	6	6	6	6
Displacement volume V_g (cm ³ /rev)	3.62	4.07	4.78	5.54	6.36	7.24

KAW 21	Permissible pressure p_{\max} (bar)	25				
	Delivery flow Q_{\max} (lpm) 50 Hz	9.92				
KAW 22	Permissible pressure p_{\max} (bar)	60				
	Delivery flow Q_{\max} (lpm) 50 Hz	9.92				
KAW 23	Permissible pressure p_{\max} (bar)	40	35	30	25	20
	Delivery flow Q_{\max} (lpm) 50 Hz	4.88	5.49	6.44	7.47	8.57
KAW 24	Permissible pressure p_{\max} (bar)	95	85	70	60	55
	Delivery flow Q_{\max} (lpm) 50 Hz	4.88	5.49	6.44	7.47	8.57
KAW 26	Permissible pressure p_{\max} (bar)	75				
	Delivery flow Q_{\max} (lpm) 50 Hz	9.92				
KAW 28	Permissible pressure p_{\max} (bar)	110	95	80	70	60
	Delivery flow Q_{\max} (lpm) 50 Hz	4.88	5.49	6.44	7.47	8.57

Gear pump Z



Note

- At a power frequency of 60 Hz, the delivery flow is approximately 1.2 times higher than that indicated here
- Be aware of different motor power ratings and resulting permissible maximum pressures $p_{\max} = (pV_g)_{\max}/V_g$ at other nominal voltages and power frequencies, $(pV_g)_{\max}$ (see [Chapter 3.2, "Electrical", Table 5](#))"

Delivery flow coding	Z 1.1	Z 1.7	Z 2.0	Z 2.7	Z 3.5	Z 4.5
Size	1	1	1	1	1	1
Displacement volume V_g (cm ³ /rev)	0.86	1.26	1.69	2.09	2.51	3.32

KAW 21	Permissible pressure p_{\max} (bar)	90	65	50	40	35	
	Delivery flow Q_{\max} (lpm) 50 Hz	2.23	3.07	3.91	5.30	6.70	
KAW 22	Permissible pressure p_{\max} (bar)	200	155	115	90	80	60
	Delivery flow Q_{\max} (lpm) 50 Hz	2.23	3.07	3.91	5.30	6.70	8.65
KAW 23	Permissible pressure p_{\max} (bar)	135	95	70	55	50	35
	Delivery flow Q_{\max} (lpm) 50 Hz	1.09	1.50	1.90	2.58	3.26	4.22
KAW 24	Permissible pressure p_{\max} (bar)	200	200	175	140	125	90
	Delivery flow Q_{\max} (lpm) 50 Hz	1.09	1.50	1.90	2.58	3.26	4.22
KAW 26	Permissible pressure p_{\max} (bar)	200	185	135	110	95	70
	Delivery flow Q_{\max} (lpm) 50 Hz	2.23	3.07	3.91	5.30	6.70	8.65
KAW 28	Permissible pressure p_{\max} (bar)	200	200	200	160	140	105
	Delivery flow Q_{\max} (lpm) 50 Hz	1.09	1.50	1.90	2.58	3.26	4.22

Gear pump Z



Note

- At a power frequency of 60 Hz, the delivery flow is approximately 1.2 times higher than that indicated here
- Be aware of different motor power ratings and resulting permissible maximum pressures $p_{\max} = (pV_g)_{\max}/V_g$ at other nominal voltages and power frequencies, $(pV_g)_{\max}$ (see [Chapter 3.2, "Electrical", Table 5](#))"

Delivery flow coding	Z 5.2	Z 6.4	Z 6.9	Z 8.8	Z 9.8	Z 11.3
Size	1	1	1	1	1	1
Displacement volume V_g (cm ³ /rev)	3.61	4.39	4.79	6.21	7.01	7.89

KAW 21	Permissible pressure p_{\max} (bar)					
	Delivery flow Q_{\max} (lpm) 50 Hz					
KAW 22	Permissible pressure p_{\max} (bar)	55	45	40	30	
	Delivery flow Q_{\max} (lpm) 50 Hz	10.04	12.28	13.39	17.02	
KAW 23	Permissible pressure p_{\max} (bar)	35				
	Delivery flow Q_{\max} (lpm) 50 Hz	4.90				
KAW 24	Permissible pressure p_{\max} (bar)	85	70	65	50	40
	Delivery flow Q_{\max} (lpm) 50 Hz	4.90	5.98	6.53	8.30	9.52
KAW 26	Permissible pressure p_{\max} (bar)	65	55	50	35	35
	Delivery flow Q_{\max} (lpm) 50 Hz	10.04	12.28	13.39	17.02	19.53
KAW 28	Permissible pressure p_{\max} (bar)	95	80	75	55	50
	Delivery flow Q_{\max} (lpm) 50 Hz	4.90	5.98	6.53	8.30	9.52

2.2.2 Dual-circuit pump with shared pedestal

a) Radial piston pump version - radial piston pump HH and radial piston pump - gear pump HZ

Order coding example:

KAW	24 1	S KS E	/ H	H	0,34	/ 2,0	- NA31 - ...	- 1x230 V 50 Hz
KA	24 11	S KS E	/ H	Z	0,34	/ 6,9	- NA31 - ...	- 3x400 V 50 Hz

Pressure connection P3 Table 4 Pressure connection P3

Pressure connection P1 Table 3 Pressure connection P1

Pressure connection P3 Table 4 Pressure connection P3: Radial piston pump H or gear pump Z

Pressure connection P1 Table 3 Pressure connection P1: Radial piston pump H

Combination options

Coding	P1	P3	Examples
HH	3 pump elements	3 pump elements	HH 0.66/1.18
	2 pump elements	4 pump elements	HH 0.34/0.86
	6 pump elements	6 pump elements	HH 0.93/0.93
	3 pump elements	9 pump elements	HH 0.47/2.01
HZ	3 pump elements	Gear pump size 1	HZ 0.33/9.8
	6 pump elements	Gear pump size 1	HZ 0.59/8.8

Table 3 Pressure connection P1



Note

- The delivery flow Q_{max} relates to the rated speed and varies depending on the load (see diagrams [Chapter 3.2, "Electrical"](#)).
- Notes on the pressures p_{max} (see [Chapter 3.2, "Electrical"](#), Table 5).
- In pump versions **HH** and **HZ**, the max. hydraulic work value $(pVg)_{max}$ is to be reduced by 10%.

Radial piston pump H

Delivery flow coding	H 0.33	H 0.47	H 0.66	H 0.91	H 1.18	H 1.51
Piston diameter (mm)	4	5	6	7	8	9
Number of pump elements	3	3	3	3	3	3
Displacement volume V_g (cm ³ /rev)	0.23	0.35	0.51	0.69	0.91	1.15
Delivery flow coding	H 0.21	H 0.34	H 0.48	H 0.62	H 0.78	H 0.99
Piston diameter (mm)	4	5	6	7	8	9
Number of pump elements	2	2	2	2	2	2
Displacement volume V_g (cm ³ /rev)	0.15	0.24	0.34	0.46	0.60	0.76
Delivery flow coding	H 0.59	H 0.93	H 1.33	H 1.81	H 2.36	H 2.99
Piston diameter (mm)	4	5	6	7	8	9
Number of pump elements	6	6	6	6	6	6
Displacement volume V_g (cm ³ /rev)	0.45	0.71	1.02	1.39	1.81	2.29

Table 4 Pressure connection P3
 **Note**

- The delivery flow Q_{\max} relates to the rated speed and varies depending on the load (see diagrams [Chapter 3.2, "Electrical"](#)).
- Notes on the pressures p_{\max} (see [Chapter 3.2, "Electrical"](#), Table 5).
- Pump version **HH** only in a vertical version
- * only in combination with coding H 0.33 ... H 1.51 (3MPE), p_{\max} at P3 = 200 bar, only in a vertical version
- Pump version **HZ** only in combination with tank size 01, 11, 02, 21, 22.

Radial piston pump H

Delivery flow coding	H 0.33	H 0.47	H 0.66	H 0.91	H 1.18	H 1.51
Piston diameter (mm)	4	5	6	7	8	9
Number of pump elements	3	3	3	3	3	3
Displacement volume V_g (cm ³ /rev)	0.23	0.35	0.51	0.69	0.91	1.15
Delivery flow coding	H 0.38	H 0.58	H 0.86	H 1.21	H 1.59	H 2.00
Piston diameter (mm)	4	5	6	7	8	9
Number of pump elements	4	4	4	4	4	4
Displacement volume V_g (cm ³ /rev)	0.30	0.47	0.68	0.92	1.21	1.53
Delivery flow coding	H 0.59	H 0.93	H 1.33	H 1.81	H 2.36	H 2.99
Piston diameter (mm)	4	5	6	7	8	9
Number of pump elements	6	6	6	6	6	6
Displacement volume V_g (cm ³ /rev)	0.45	0.71	1.02	1.39	1.81	2.29
Delivery flow coding	H 0.85	H 1.38	H 2.01	H 2.71	H 3.54	H 4.49
Piston diameter (mm)	4	5	6	7	8	9
Number of pump elements	9	9	9	9	9	9
Displacement volume V_g (cm ³ /rev)	0.68	1.06	1.53	2.08	2.71	3.44
Delivery flow coding *	H 1.84	H 2.66	H 3.12	H 3.61	H 4.14	H 4.72
Piston diameter (mm)	10	12	13	14	15	16
Number of pump elements	3	3	3	3	3	3
Displacement volume V_g (cm ³ /rev)	1.41	2.04	2.39	2.77	3.18	3.62

Gear pump Z

Delivery flow coding	Z 1.1	Z 1.7	Z 2.0	Z 2.7	Z 3.5	Z 4.5
Size	1	1	1	1	1	1
Displacement volume V_g (cm ³ /rev)	0.86	1.26	1.69	2.09	2.51	3.32
Delivery flow coding	Z 5.2	Z 6.4	Z 6.9	Z 8.8	Z 9.8	Z 11.3
Size	1	1	1	1	1	1
Displacement volume V_g (cm ³ /rev)	3.61	4.39	4.79	6.21	7.01	7.89

3.1 General

General information

Conformity	<ul style="list-style-type: none"> ▪ Declaration of incorporation according to Machinery Directive 2006/42/EC, see Chapter 6.2, "Explanations" ▪ Declaration of conformity according to Low-Voltage Directive 2006/95/EC, see Chapter 6.2, "Explanations" ▪ UL conformity of the stators - UL reference E216350 ▪ UL conformity of the external fans F, F1 - UL reference E216350 										
Designation	Hydraulic power pack										
Design	Valve-controlled radial piston pump or gear pump										
Model	Compact hydraulic power pack (closed unit with a pump, electric drive and tank)										
Material	Housing: Aluminium										
Attachment	M8 threaded holes, see dimensioned drawings										
Tightening torques	See Chapter 4, "Dimensions"										
Installation position	Vertical (KA...S) or horizontal (KA...L) Take note of the installation instructions for horizontal positioning in section 4.2.										
Rotation direction	Radial piston pump – any Gear pump – anticlockwise (Rotation direction only ascertainable from check of delivery flow; if there is no delivery flow in the three-phase version, replace two of the three main conductors)										
Speed range	<table style="width: 100%; border-collapse: collapse;"> <tr> <td style="width: 40%;">Radial piston pump H:</td> <td style="text-align: right;">100 ... 3500 rpm</td> </tr> <tr> <td colspan="2">Gear pump</td> </tr> <tr> <td>Z 1.1 ... Z 2.7:</td> <td style="text-align: right;">800 to 4000 rpm</td> </tr> <tr> <td>Z 3.5 ... Z 8.4:</td> <td style="text-align: right;">500 ... 3800 rpm</td> </tr> <tr> <td>Z 8.8 ... Z 11.3</td> <td style="text-align: right;">500 ... 3500 rpm</td> </tr> </table>	Radial piston pump H:	100 ... 3500 rpm	Gear pump		Z 1.1 ... Z 2.7:	800 to 4000 rpm	Z 3.5 ... Z 8.4:	500 ... 3800 rpm	Z 8.8 ... Z 11.3	500 ... 3500 rpm
Radial piston pump H:	100 ... 3500 rpm										
Gear pump											
Z 1.1 ... Z 2.7:	800 to 4000 rpm										
Z 3.5 ... Z 8.4:	500 ... 3800 rpm										
Z 8.8 ... Z 11.3	500 ... 3500 rpm										
Line connection	only via the screwed-on connection blocks, see selection table in Chapter 6.1, "Planning information" ("Selection of the connection blocks") Basic pump: Connection drilling pattern, see Chapter 4.3, "Electrical and hydraulic connections"										

Silica gel filters	<table border="0"> <tr> <td>Filter area</td> <td>26.6 cm²</td> </tr> <tr> <td>Quantity</td> <td>125 g</td> </tr> <tr> <td>Absorption capacity</td> <td>150 ml</td> </tr> <tr> <td>Filtration</td> <td>3 μm</td> </tr> <tr> <td>Temperature range</td> <td>-30°C ... +90°C</td> </tr> </table> <div style="border: 1px solid gray; padding: 5px; margin-top: 10px;"> <p>Note  Take note of the maintenance information in Chapter 5.4, "Maintenance information"!</p> </div>	Filter area	26.6 cm ²	Quantity	125 g	Absorption capacity	150 ml	Filtration	3 μm	Temperature range	-30°C ... +90°C
Filter area	26.6 cm ²										
Quantity	125 g										
Absorption capacity	150 ml										
Filtration	3 μm										
Temperature range	-30°C ... +90°C										
Hydraulic fluid	<p>Hydraulic oil: according to DIN 51 524 Part 1 to 3; ISO VG 10 to 68 according to DIN 51 519 Viscosity range: min. approx. 4; max. approx. 800 mm²/s Optimal operating range: approx. 10 ... 500 mm²/s Also suitable for biologically degradable pressure fluids type HEPG (polyalkylene glycol) and HEES (synthetic ester) at operating temperatures up to approx. +70°C.</p>										
Cleanliness level	<p>ISO 4406 <hr style="width: 50%; margin-left: 0;"/> 21/18/15...19/17/13</p>										
Temperature	<p>Ambient: approx. -40 ... +80°C, Fluid: -25 ... +80°C, Note the viscosity range! Permissible temperature during start: -40°C (observe start-viscosity!), as long as the service temperature is at least 20K higher for the following operation. Biologically degradable pressure fluids: Observe manufacturer's specifications. By consideration of the compatibility with seal material not over +70°C.</p>										

Weight

(without oil filling)

Type	H (3 cylinders)	H (6 cylinders)	Z	HZ
KA 21, 23	10.9 kg	11.5 kg	12.7 kg	13.2 kg
KA 22, 24	13.2 kg	13.6 kg	15.0 kg	15.5 kg
KA 26, 28, 29	14.7 kg	15.1 kg	16.5 kg	17.0 kg

Weight of the required connection blocks and valve banks, see the relevant publications, see [Chapter 6.1, "Planning information"](#) ("Selection of connection blocks") and ("Selection of directional valve banks")

Tank size 01, 1	+ 0.7 kg
Tank size 02, 2	+ 2.2 kg
Tank size 11	+ 1.4 kg
Tank size 21	+ 2.9 kg
Tank size 22, 3	+ 4.4 kg
External fans F, F1	+ 1.8 kg
External side fans FSL, FSR, FSH	+ 0.54 kg (1x110 V, 1x230 V) + 0.22 kg (24 V DC)
External side fan FSLR	+ 1.1 kg (1x110 V, 1x230 V) + 0.45 kg (24 V DC)

Characteristics

Running noises

Radial piston pump

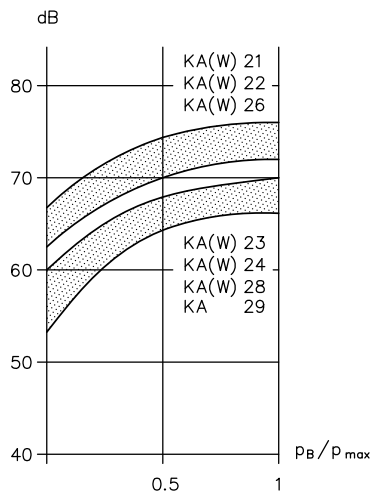

p_B/p_{max} pressure ratio; dB noise level (A)

$\frac{p_B}{p_{max}}$ Dackvehältnis

Gear pump

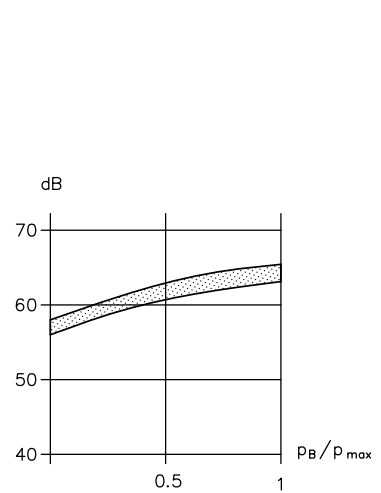

p_B/p_{max} pressure ratio; dB noise level (A)

$\frac{p_B}{p_{max}}$ Dackvehältnis

3.2 Electrical

Data applies to radial piston and gear pumps

The drive motor forms a closed, inseparable unit with the pump, see description [Chapter 1, "Overview compact hydraulic power pack type KA2 and KAW2"](#).

Port	<ul style="list-style-type: none"> For version with HARTING plug cable 1.5 mm² For version with integrated terminal boxes, flat plug sleeve 6.3 AMP (cable fitting M 20x1.5 or M12x1 (PM option) must be provided by the customer) 							
Protection class	IP 65 in accordance with IEC 60529							
	<p>Note The breather filter must be safeguarded against moisture penetration</p>							
Protection class	VDE 0100 protection class 1							
Insulation	<p>Designed in accordance with EN 60 664-1</p> <ul style="list-style-type: none"> For 4 wire AC voltage systems L1-L2-L3-PE (3-phase systems) with an earthed neutral point up to 500 V AC nominal phase voltage phase-phase For 3-wire AC voltage systems L1-L2-L3 (3-phase systems) without an earthed neutral point up to a nominal phase voltage of 300 V AC phase-phase For a single-phase and earthed 2-wire alternating current system L-N (alternating current or mains) up to a nominal voltage of 300 V AC. 							
Suppressor	Type RC 3 R							
Coding E, PE	<table border="0"> <tr> <td>Operating voltage</td> <td>3x 575 V AC</td> </tr> <tr> <td>Frequency</td> <td>10 to 400 Hz</td> </tr> <tr> <td>max. motor power</td> <td>4.0 kW</td> </tr> </table>	Operating voltage	3x 575 V AC	Frequency	10 to 400 Hz	max. motor power	4.0 kW	
Operating voltage	3x 575 V AC							
Frequency	10 to 400 Hz							
max. motor power	4.0 kW							

Table 5 Motor data
3-phase motor

Type	Nominal voltage and power frequency U_N (V), f (Hz)	Nominal power P_N (kW)	Rated speed n_N (rpm)	Nominal current I_N (A)	Starting current ratio I_A / I_N	Power factor $\cos \varphi$	Hydraulic work value $(pV_g)_{\max}$ (bar cm ³)
KA 21	3x400 V 50 Hz / 3x460 V 60 Hz	0.55 / 0.66	2790 / 3350	1.25 / 1.3	4.8 / 5.4	0.84 / 0.88	165 / 165
	3x230 V 50 Hz	0.55	2790	2.2	4.8	0.84	165
	3x690 V 50 Hz Υ	0.55	2790	0.73	4.8	0.84	165
KA 22	3x400 V 50 Hz / 3x460 V 60 Hz	1.1 / 1.32	2790 / 3400	2.7 / 2.6	5.4 / 7.1	0.83 / 0.80	520 / 520
	3x230 V 50 Hz	1.32	2790	4.7	5.4	0.83	520
	3x690 V 50 Hz Υ	1.1	2790	1.55	6.3	0.83	490
	3x200 V 50 Hz / 3x220 V 60 Hz *	1.1 / 1.1	2820 / 3380	5.5 / 4.9	5.4 / 6.2	0.74 / 0.88	490 / 350
KA 23	3x400 V 50 Hz / 3x460 V 60 Hz	0.37 / 0.44	1360 / 1650	1.0 / 1.0	4.3 / 4.4	0.80 / 0.81	220 / 220
	3x230 V 50 Hz	0.37	1360	1.75	4.3	0.80	220
	3x690 V 50 Hz Υ S3	0.75	1330	1.3	3.0	0.75	385
	3x575 V 60 Hz Υ S3	0.75	1670	1.4	3.8	0.75	360
	3x200 V 50 Hz / 3x220 V 60 Hz *	0.37 / 0.37	1410 / 1690	2.3 / 2.0	4.8 / 4.8	0.67 / 0.67	290 / 210
KA 24	3x400 V 50 Hz / 3x460 V 60 Hz	0.75 / 0.9	1360 / 1650	2.2 / 2.1	4.3 / 5.4	0.74 / 0.74	590
	3x230 V 50 Hz	0.75	1360	3.8	4.3	0.74	590
	3x500 V 50 Hz / 3x575 V 60 Hz	0.75 / 0.9	1400 / 1700	1.8 / 1.6	4.3 / 4.8	0.71 / 0.68	590 / 590
	3x200 V 50 Hz / 3x220 V 60 Hz *	0.75 / 0.75	1390 / 1680	4.5 / 3.9	4.8 / 4.8	0.67 / 0.67	610 / 460
KA 26	3x400 V 50 Hz / 3x460 V 60 Hz	1.4 / 1.68	2810 / 3340	3.3 / 3.0	5.1 / 5.0	0.82 / 0.90	585
	3x230 V 50 Hz	1.4	2810	5.7	5.1	0.82	585
	3x500 V 50 Hz / 3x575 V 60 Hz	1.4 / 1.4	2820 / 3450	2.35 / 2.0	6.0 / 7.1	0.85 / 0.86	590 / 590
	3x380 V 60 Hz Υ	1.4	3450	3.05	7.1	0.86	630
	3x200 V 50 Hz / 3x220 V 60 Hz *	1.4 / 1.4	2840 / 3450	6.4 / 5.3	6.2 / 7.1	0.79 / 0.86	630 / 630
KA 28	3x400 V 50 Hz / 3x460 V 60 Hz	1.2 / 1.45	1380 / 1680	3.4 / 3.2	4.8 / 5.0	0.76 / 0.78	870 / 870
	3x230 V 50 Hz	1.2	1380	5.9	4.8	0.76	870
	3x200 V 50 Hz / 3x220 V 60 Hz *	1.1 / 1.1	1390 / 1690	6.3 / 5.5	5.1 / 5.1	0.67 / 0.76	785 / 665
KA 29	3x400 V 50 Hz	1.6 / 1.92	1390 / 1690	6.7 / 6.2	3.8 / 3.8	0.54 / 0.54	1250 / 1250
	3x230 V 50 Hz	1.6	1390	11.6	3.8	0.54	1250
	3x200 V 50 Hz / 3x220 V 60 Hz *	1.6 / 1.92	1400 / 1680	12.5 / 10.8	3.9 / 3.9	0.55 / 0.55	1225 / 1060

* Motors for 200 V 50 Hz or 220 V 60 Hz networks (Japan)

Re. Table 5 Motor data
Single-phase-motor

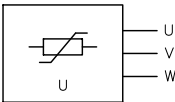
Type	Nominal voltage and power frequency U_N (V), f (Hz)	Nominal power P_N (kW)	Rated speed n_N (rpm)	Nominal current I_N (A)	Starting current ratio I_A / I_N	Power factor $\cos \varphi$	Recommended operating capacitor C_B (μ F)	Hydraulic work value $(pV_g)_{\max}$ (bar cm^3)
KAW 21	1x230 V 50 Hz \perp	0.37	2770	2.5	3.7	0.97	16	100
	1x110 V 60 Hz \perp	0.37	3340	5.5	3.0	0.96	50	70
KAW 22	1x230 V 50 Hz \perp	0.75	2810	4.75	4.4	0.94	25	315
	1x110 V 60 Hz \perp	0.75	3400	12.0	3.5	0.90	120	225
	1x220 V 60 Hz \perp	0.75	3400	6.0	3.5	0.90	30	230
	1x115 V 50 Hz \perp	0.75	2810	9.5	4.4	0.94	100	225
KAW 23	1x230 V 50 Hz \perp	0.25	1380	1.9	3.0	0.91	12	145
	1x110 V 60 Hz \perp	0.25	1650	4.4	3.2	0.96	50	100
KAW 24	1x230 V 50 Hz \perp	0.5	1390	4.1	2.9	0.95	16	350
	1x110 V 60 Hz \perp	0.5	1680	9.0	3.3	0.98	50	210
	1x220 V 60 Hz \perp	0.5	1680	3.9	2.9	0.98	25	275
KAW 26	1x230 V 50 Hz \perp	1.1	2770	7.2	4.8	0.98	25	275
	1x110 V 60 Hz \perp	1.1	3340	15.0	4.0	0.99	80	235
	1x220 V 60 Hz \perp	1.1	3340	7.2	4.0	0.99	20	275
	1x115 V 50 Hz \perp	1.1	2750	15.0	4.0	0.96	100	260
KAW 28	1x230 V 50 Hz \perp	0.7	1370	5.1	3.0	0.94	20	400
	1x110 V 60 Hz \perp	0.7	1650	10.5	3.0	0.98	80	315

i Note

- The current consumption of the motor is dependent on the load. The nominal values only apply for one operating point. In modes S2 and S3 the motor may be used at up to about 1.8 times its nominal capacity. The heat development which is increased here is cooled in the no-load phases or during stoppage times.
- The current and pump delivery flow can be estimated on the basis of the medium and maximum hydraulic work values $(pV_g)_m$ and $(pV_g)_{max}$.
- The relevant load case is responsible for current consumption in dual-circuit pumps. The hydraulic work of the individual circuits is to be determined and added.

All connections
pressurised:



One connection
pressurised, the
other one deliver-
ing in circulation
mode:

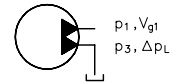

Dual-circuit pumps $(pV_g)_{calc} = p_1 V_{g1} + p_3 V_{g3}$

Dual-circuit pumps $(pV_g)_{calc} = p_1 V_{g1} + \Delta p_L V_{g3}$

- Versions with single-phase motors
Actual current consumption is also dependent on the size of the operating capacitor
The operating capacitor is not included in the scope of supply. Re. the design, see [Chapter 6.1, "Planning information"](#) ("Selection of the operating capacitor for the KAW type")
- Re. the specification for the operating capacitor
 - 1x230 V 50 Hz - ... μF / 400 V DB
 - 1x220 V 60 Hz - ... μF / 400 V DB
 - 1x115 V 50 Hz - ... μF / 230 V DB
 - 1x110 V 60 Hz - ... μF / 230 V DB
- Voltage tolerances: $\pm 10\%$ (IEC 38), at 3x460/265 V 60 Hz $\pm 5\%$
It can be operated at undervoltage; take note of information about performance restrictions in [Chapter 6.1, "Planning information"](#) ("Selection of a compact hydraulic power pack")!
- In the pump version **Z**, **HH** or **HZ**, the maximum hydraulic work value $(pV_g)_{max}$ is to be reduced by 10%.

Current consumption

KA 23, KA 24, KA 28, KA 29

Operating voltage 3x400/230 V 50 Hz $\Upsilon\Delta$
3x460/265 V 60 Hz $\Upsilon\Delta$

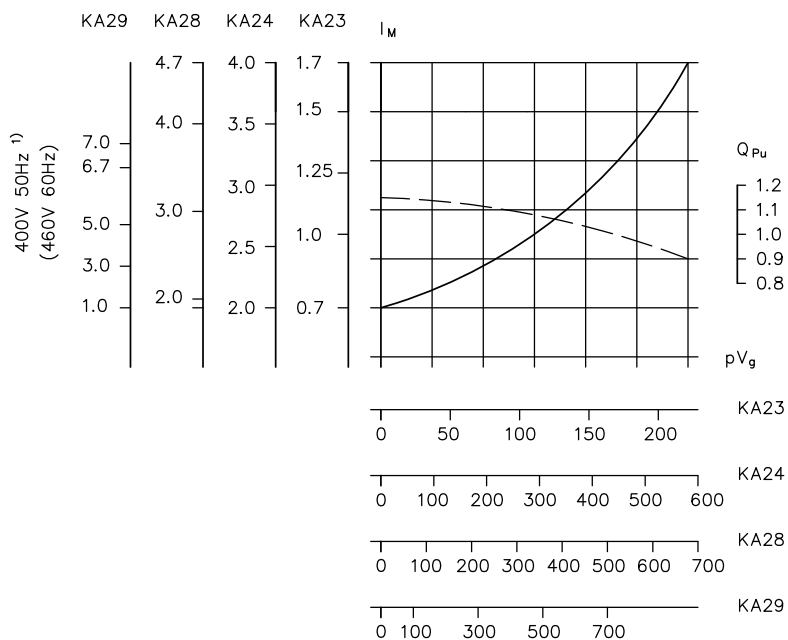

pV_g hydraulic work value (bar cm^3); I_M motor current (A); Q_{PU} delivery flow characteristic (trend) 1.0

KA 21, KA 22, KA 26

Operating voltage 3x400/230 V 50 Hz $\Upsilon\Delta$
3x460/265 V 60 Hz $\Upsilon\Delta$

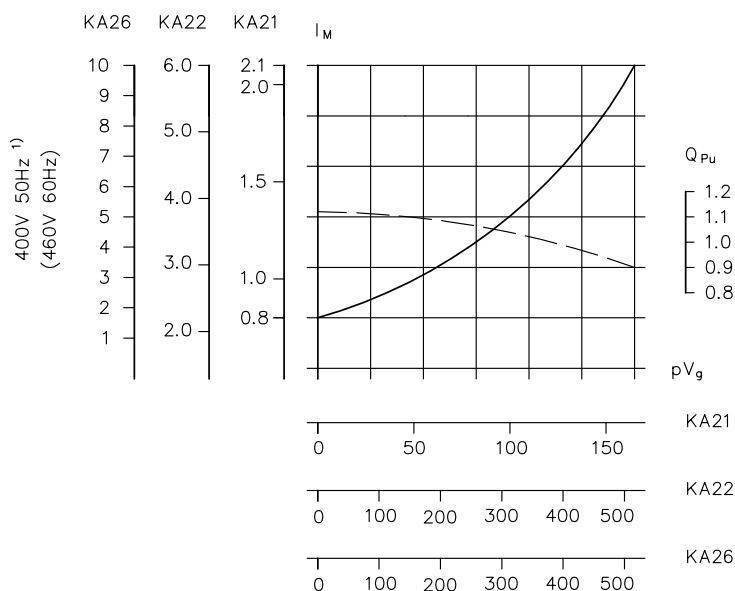

pV_g hydraulic work value (bar cm^3); I_M motor current (A); Q_{PU} delivery flow characteristic (trend) 1.0

1) Values at 230 V Δ are the values times $\sqrt{3}$

KAW 23, KAW 24, KAW 28

Operating voltage 1x230 V 50 Hz
1x110 V 60 Hz

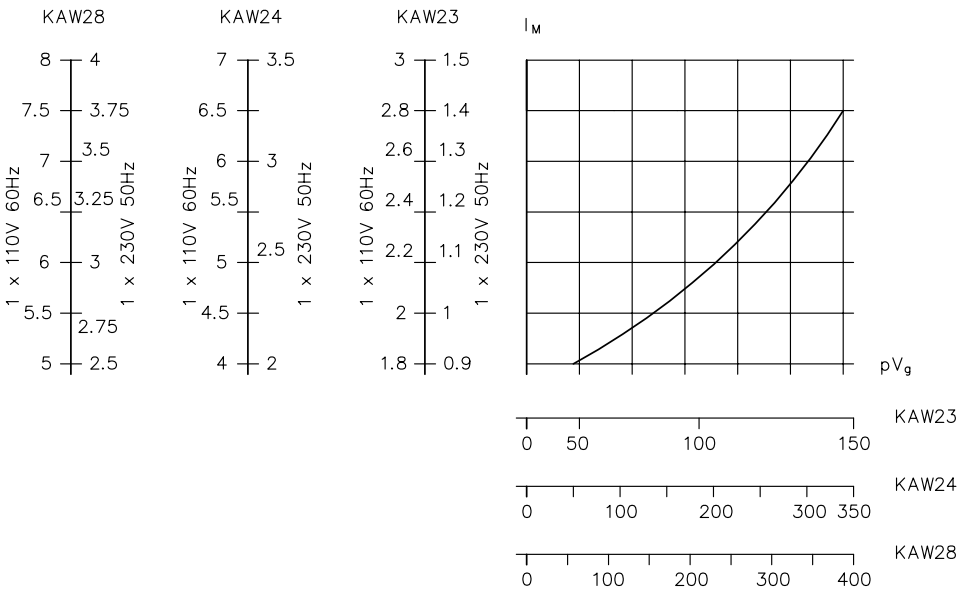

pV_g hydraulic work (bar cm^3); I_M motor current (A);

KAW 21, KAW 22, KAW 26

Operating voltage 1x230 V 50 Hz
1x110 V 60 Hz

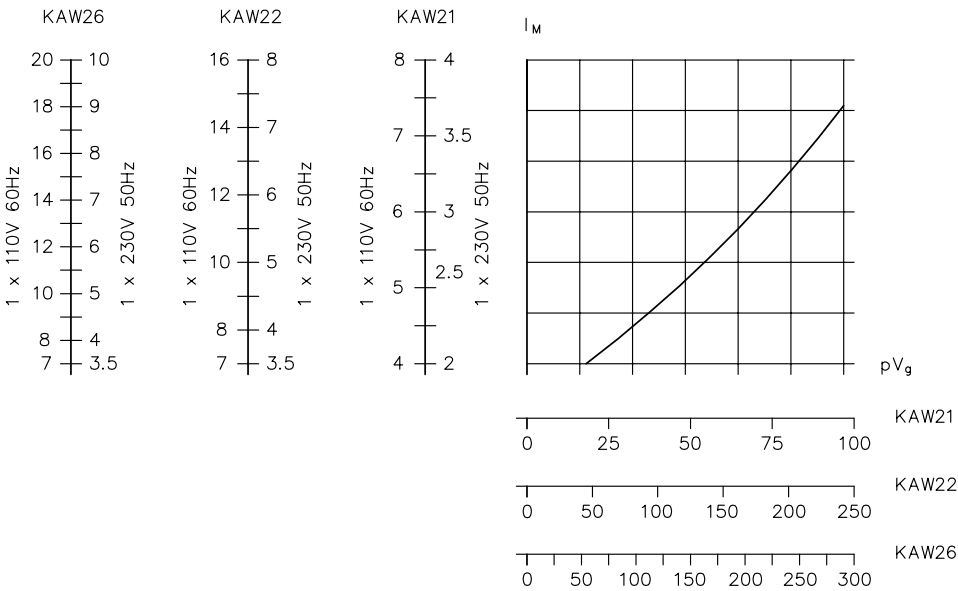

pV_g hydraulic work (bar cm^3); I_M motor current (A);

Temperature switches

Coding **T, T50, T60, TT50, TT60**

Technical data:

Bimetallic-element switch
 designed as a winding protection contact (type KAW)
 designed as a separate temperature switch (type KA)



Signal indication	80°C ± 5K (coding T) 60°C ± 5K (coding T60) 50°C ± 5K (coding T50)
Max. voltage	600 V
Nominal current (cos φ ~ 0.95 / 0.6)	2.5 A / 1.6 A
Max. current at 24 V (cos φ = 1)	1.5 A
Electrical connection	At the terminal box / HARTING plug

Level switch

coding **D, S** (horizontal)

Technical data:

Max. DC/AC switching capacity	30 VA	D	S
Max. DC/AC current	0.5 A (cos φ = 1)	(N/C contact)	(N/O contact)
Max. voltage	230 V AC/DC		

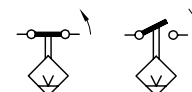

Electrical connection At the terminal box / HARTING plug

coding **KD, KS** (vertical)

DC/AC switching capacity	10 W
Max. DC/AC current	1 A
Max. voltage	150 V 50/60 Hz 200 V DC
Electrical connection	Line connector industry standard contact gap 9.4 mm M12x1, 5-pin (coding M, M1, M2, PM, PM1, PM2)

A protective circuit is to be implemented in the case of an inductive load!

Fan
coding **F, F1**

Motor data

U _N	P _N (W)	Speed [rpm]	Protection class
1x230 V 50/60 Hz ⊥	45	2800/3250	IP 44
1x110 V 60 Hz ⊥	38	3250	IP 44
24 V DC	12	3050	IP 20

Temperature range -30°C ... +50°C

Electrical connection Male connector re. DIN EN 175 301-803 A

Coding **FSL, FSR, FSH, FSLR**

Motor data

U _N	P _N (W)	Speed [rpm]	Protection class
1x230 V 50/60 Hz ⊥	19	2650/3100	IP 68
1x110 V 50/60 Hz ⊥	19	2650/3100	IP 68
24 V DC	5	2800	IP 68

Electrical connection Tyco TE 776428-1 (24 V DC)
Tyco TE 776428-2 (1x .. V ⊥)

4 Dimensions

All dimensions in mm, subject to change.

4.1 Mounting hole pattern

Horizontal version coding L

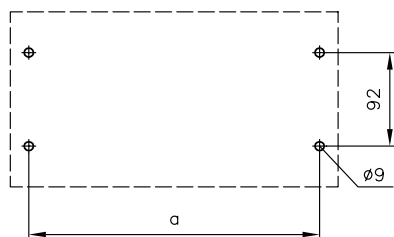

Tank size	a
--	284
01, 1	336
11	388
02, 2	484
22, 3	684

Vertical version coding S

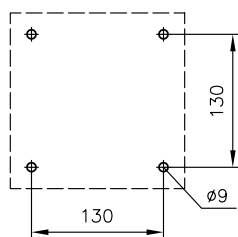

Recommended attachment

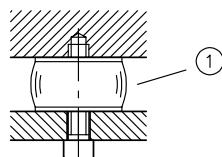

1 Damping element $\varnothing 40 \times 30 / M8$ (65 Shore)

4.2 Basic pump

Vertical version

Tank size (without coding)

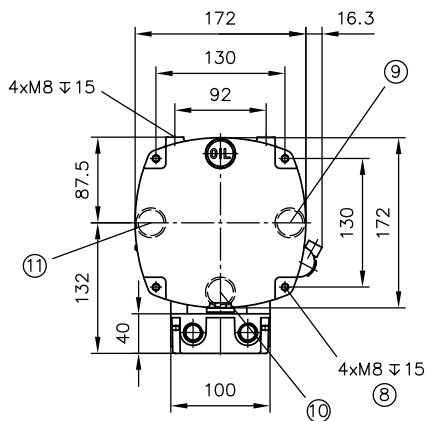
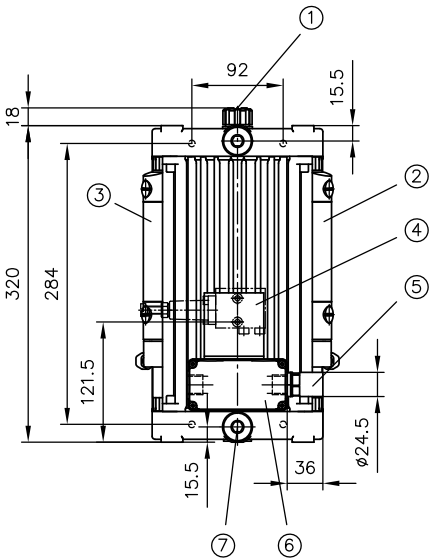

- 1 Oil filler G 1/2 (BSPP)
Breather filter (40 µm)
- 2 Level gauge K, KS, KD
- 3 Level gauge K1, K1S, K1D
- 4 Pedestal with a connection block; example: A 1 / ...
- 5 Suppressor coding E
- 6 Terminal box coding P
- 7 Oil drain G 1/2 (BSPP)
- 8 4x at both ends Attachment holes
- 9 Installation position coding S14
- 10 Installation position coding S25
- 11 Installation position coding S36

Tank size coding 1

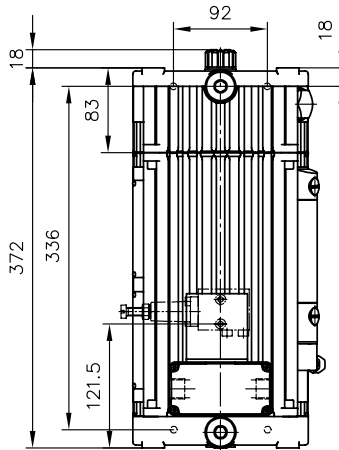

In the case of a tank size of 1, 2, 11, 21, 3 and an additional level gauge coding K, KS, KD, an additional display is to be integrated into the extension.

Tank size coding 2

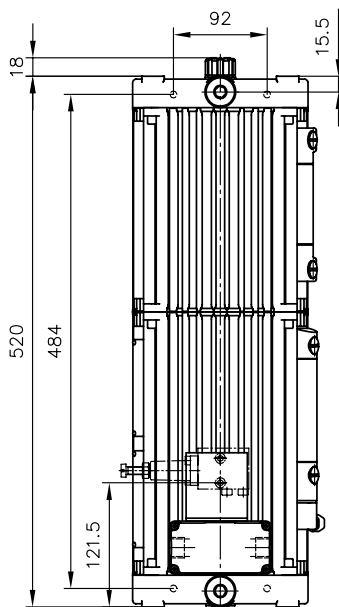

Tank size coding 3

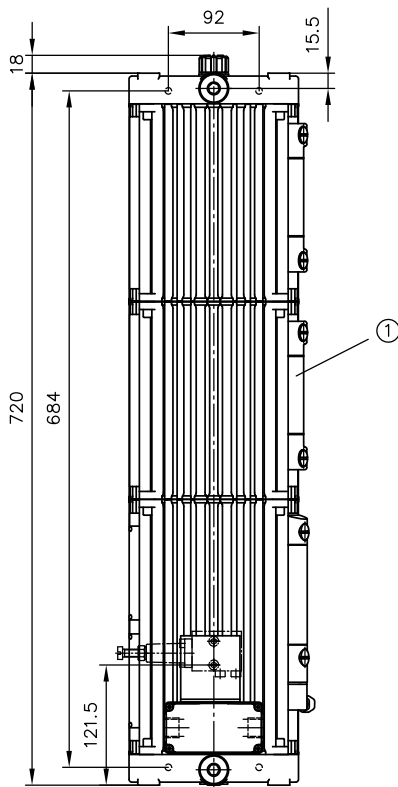

1 With coding KK

Tank size coding 11

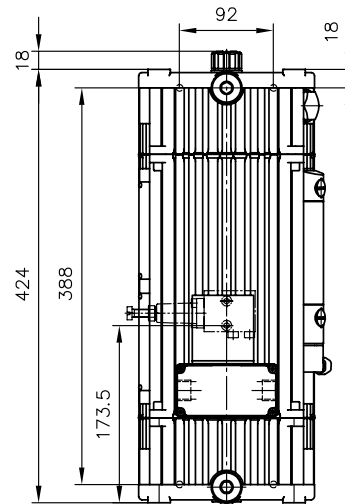

Tank size coding 01

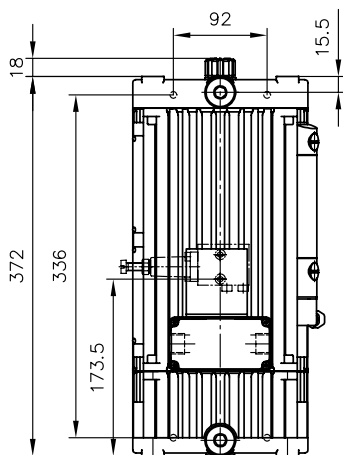

Tank size coding 21

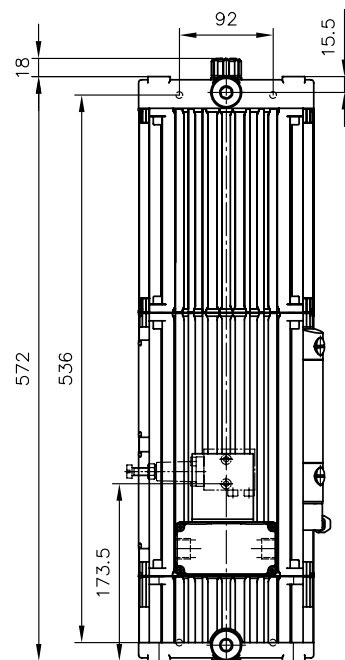

Horizontal version

Tank size (without coding)

Installation position coding **L1 (L14)**

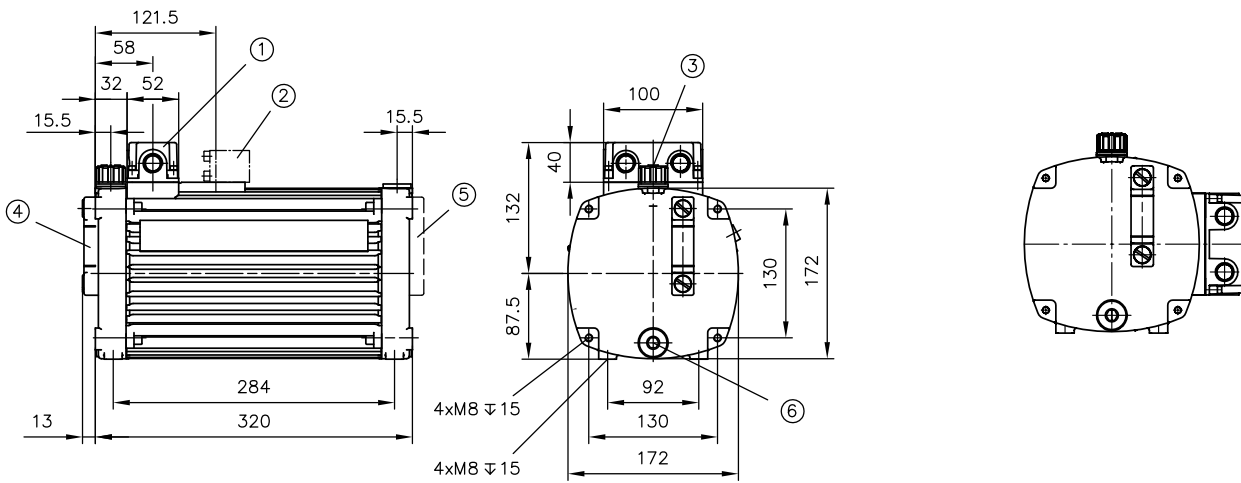

- 1 Terminal box
- 2 Example of a connection block A1/...
- 3 Oil filler G 1/2 (BSPP)
Breather filter (40 µm)
- 4 Level gauge K (installation position coding L, L1)
- 5 Level gauge K (installation position coding L4, L14)
- 6 Oil drain G 1/2 (BSPP)

Tank size coding **1**

Tank size coding **2**

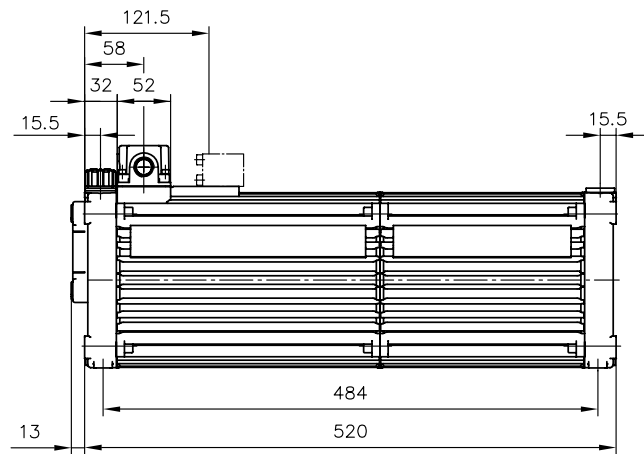
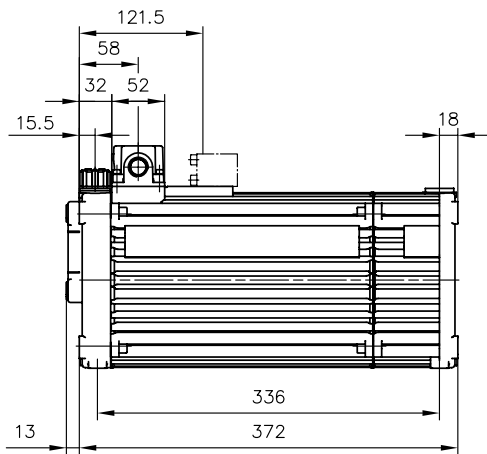

Tank size coding **3**

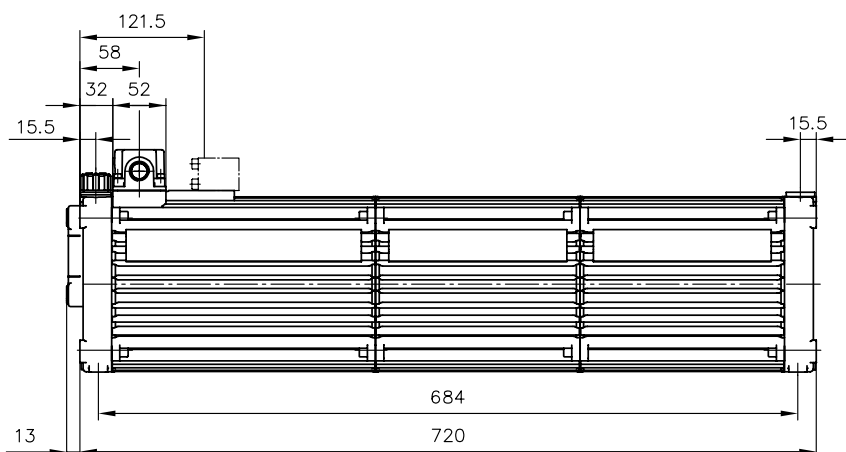

Tank size coding **01**

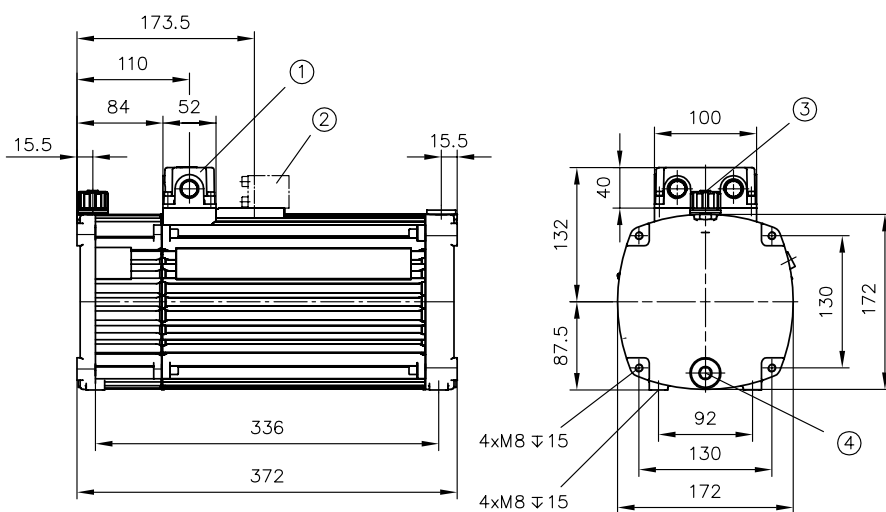

- 1 Terminal box
- 2 Example of a connection block A1/...
- 3 Oil filler G 1/2 (BSPP)
Breather filter (40 μm)
- 4 Oil drain G 1/2 (BSPP)

i Note

If a horizontal version is used in a vertical position, ensure that the vent is on top and the built-in internal pump is at the bottom.

Tank size coding **11**

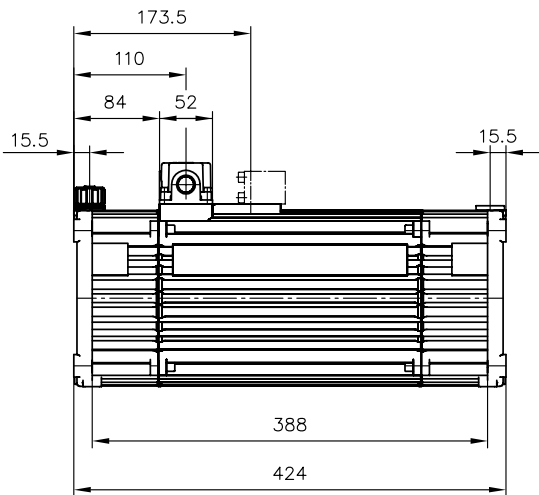

Tank size coding **02**

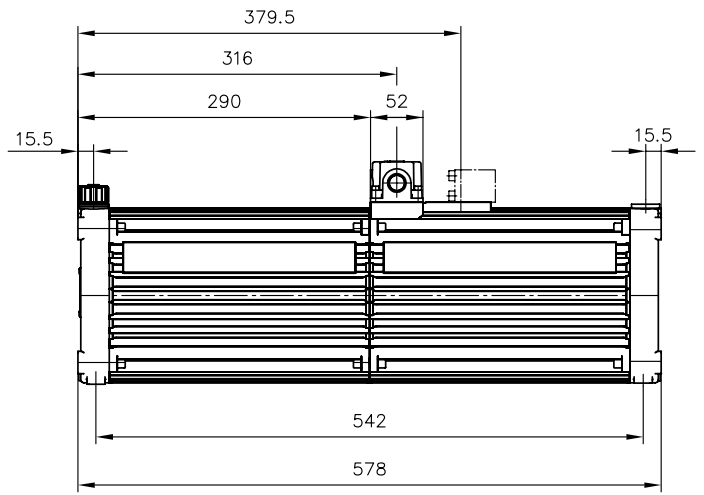

Tank size coding **22**

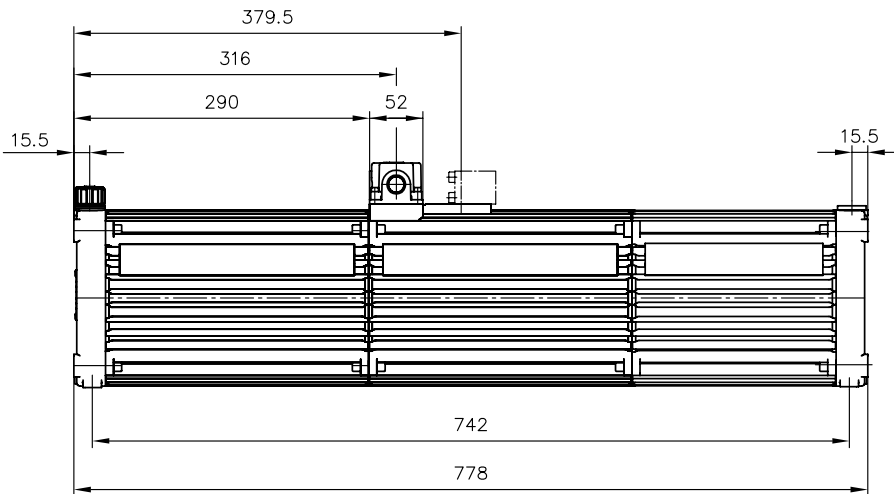

Additional option

Terminal box

Coding P

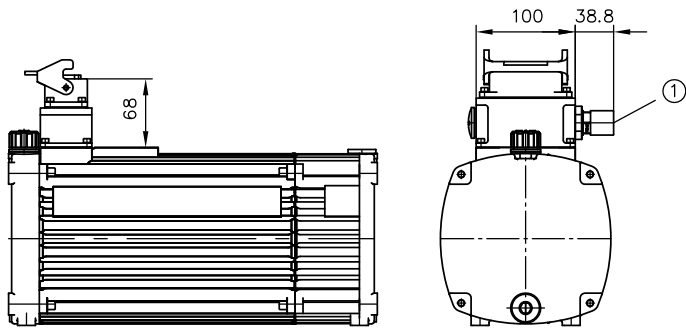

1 Suppressor coding PE

Silica gel filters

Coding G

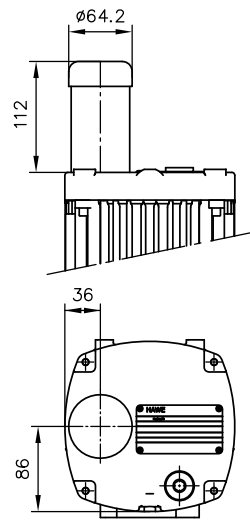

Terminal box

M12 connections for temperature and/or level switch

Coding M, PM

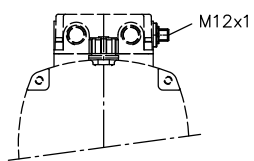

Coding M1, PM1

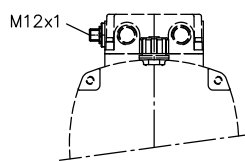

Coding M2, PM2

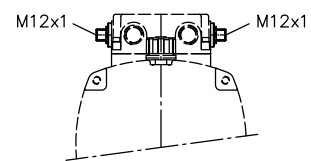

Fan

Coding F, F1

horizontal version

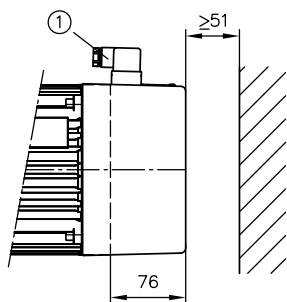

1 Electrical connection to fan

vertical version

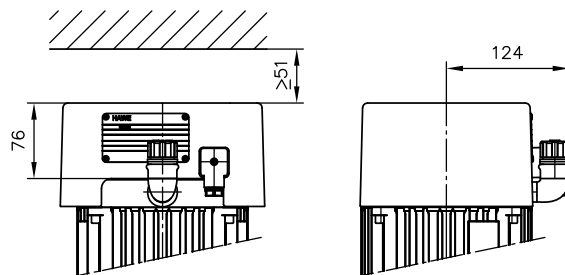

Fan

Coding **FSL, FSR, FSLR, FSH**

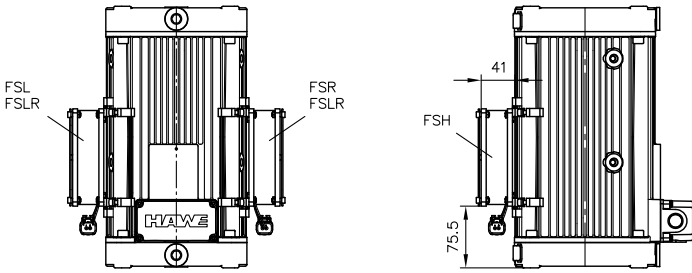

Filler reduction

Coding **B**

horizontal version

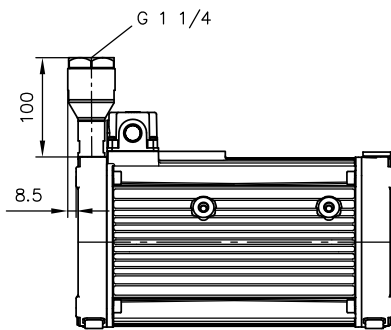

vertical version

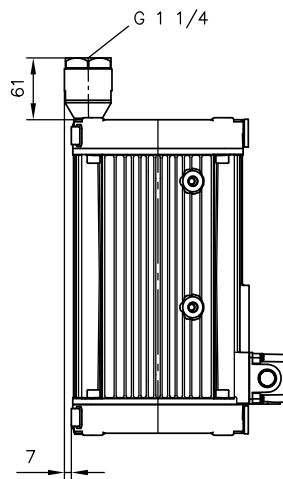

Coding **B1**

horizontal version

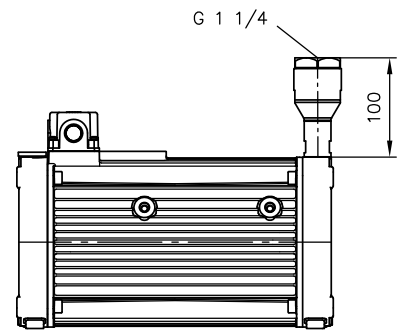

Oil drain hose

Coding **G 1/2 x 300**
G 1/2 x 500

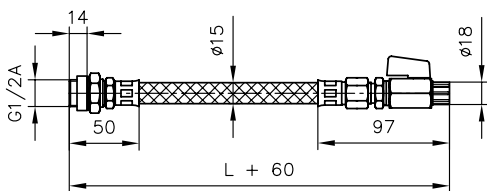

Coding **G 1/2 W x 300**
G 1/2 W x 500

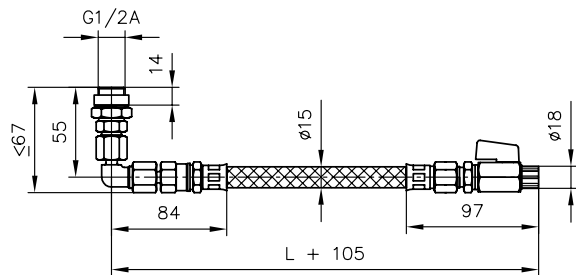

4.3 Electrical and hydraulic connections

Hydraulic

Single-circuit pump

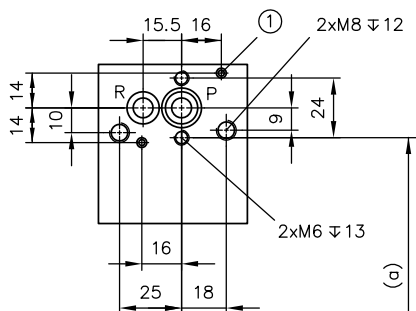

1 Centring pin $\varnothing 4$ mm

a = 121.5

Dual-circuit pump with shared pedestal

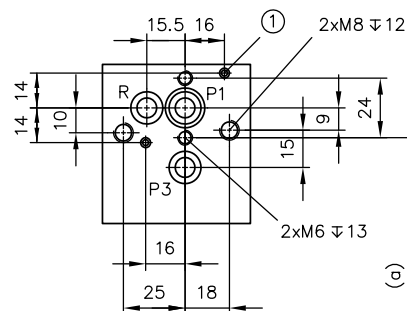

1 Centring pin $\varnothing 4$ mm

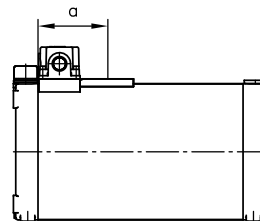

Hole for self-made connection block

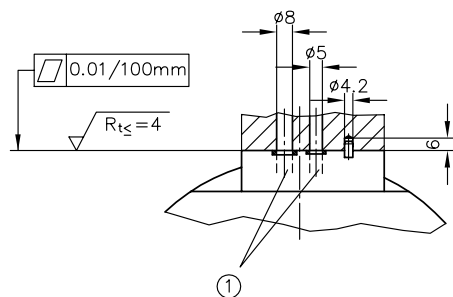

1 Sealing of connections:

P, P1, P3, R = 8x2 NBR 90 Sh

Electrical

Terminal box

3-phase motor

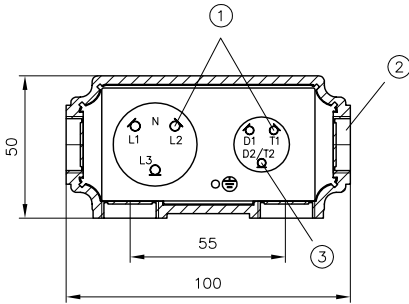

- 1 Flat plug
- 2 4x cable fittings M20x1.5
- 3 For vertical version (only D2/T2-T1)

Single-phase-motor

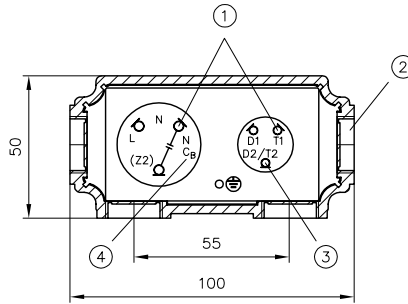

- 1 Flat plug
- 2 4x cable fittings M20x1.5
- 3 For vertical version (only D2/T2-T1)
- 4 C_B – operating capacitor is not included in the scope of delivery

Temperature switches

Coding **T**
(Terminal box)

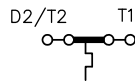

Coding **TT50, TT60**

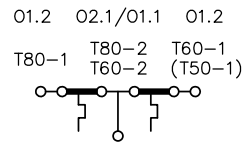

Level switch

Coding **ST**
(Terminal box)

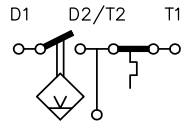

Coding **DT**
(Terminal box)

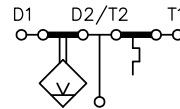

Coding **S, D**

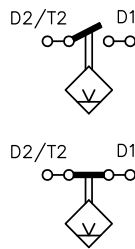

Coding **DD**

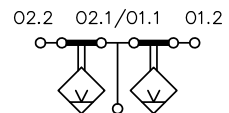

Coding P
Harting plug HAN 10 E

3-phase motor

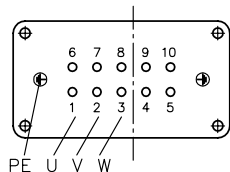

Single-phase-motor

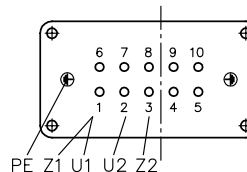

Customer-side connection (male connector)

3-phase motor Υ

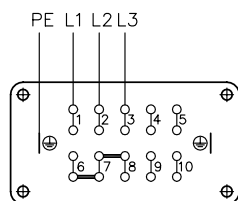

3-phase motor Δ

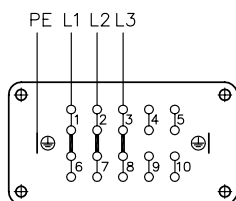

Single-phase-motor

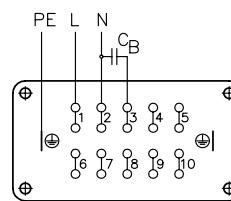

C_B – operating capacitor is not included in the scope of delivery

Coding D, S

D (N/C contact)

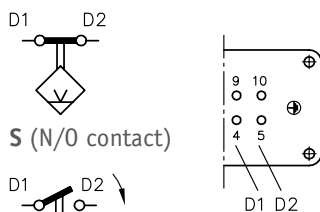

S (N/O contact)



Coding T

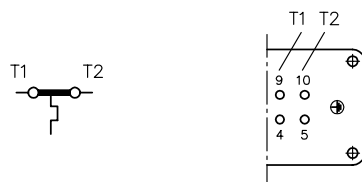

Coding DT, ST

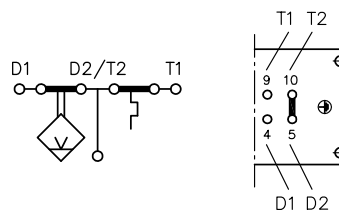

Coding TT50, TT60

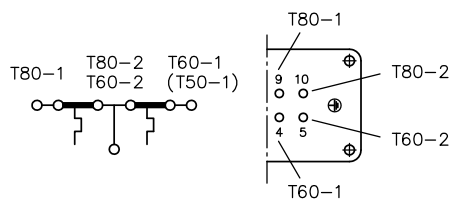

Coding **M, M1, PM, PM1**

Harting plug HAN 10 E (see page 41)

Additional connection M12x1, 4-pin

Coding **T**

One temperature switch:

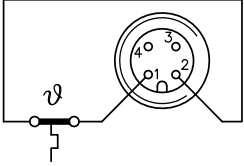

Coding **TT50, TT60**

Two temperature switches:

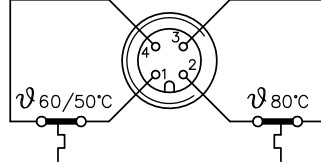

Coding **D, S**

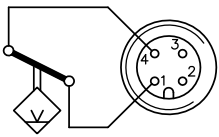

Coding **DT, ST**

One temperature switch and one level switch (horizontal version):

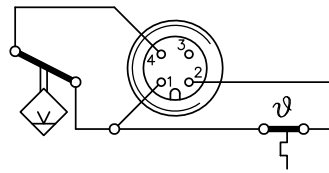

Coding **M2, PM2**

Harting plug HAN 10 E (see page 41)

2x additional connections M12x1, 4-pin

Coding **DT, ST**

One temperature switch and one level switch (horizontal version):

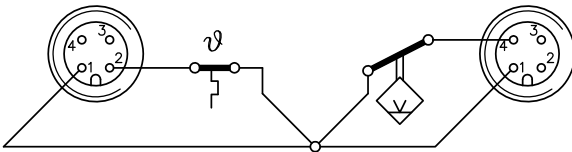

Level switch (vertical version)

Coding **KS, KD**

Line connector

Industry standard

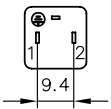

KS (N/O contact)

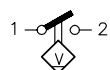

KD (N/C contact)

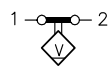

M12x1, 5-pin (coding **PM**)

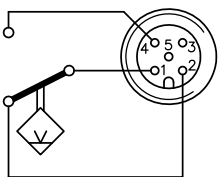

Coding **KDD**

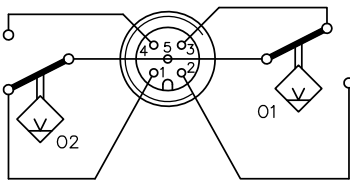

Fan

Coding **F, F1**

1x230 V 50/60 Hz ⊥
1x110 V 60 Hz ⊥

Line connector
DIN EN 175 301-803 A

24V DC

Line connector
DIN EN 175 301-803 A

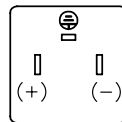
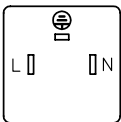

Side fan

Coding **FS ...**

1x230 V 50/60 Hz ⊥
1x115 V 50 Hz ⊥
1x110 V 60 Hz ⊥

Tyco line connector
TE 776427-1

24V DC

Tyco line connector
TE 776427-2

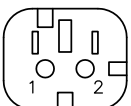

5.1 Intended use

This hydraulic component is exclusively intended for hydraulic applications (fluid engineering).

These hydraulic components meet high technical safety standards and regulations for fluid engineering and electrical engineering.

The user must observe the safety measures and warnings in this documentation.

Essential requirements for the product to function correctly and safely:

- All information in this documentation must be observed. This applies in particular to all safety measures and warnings.
- The product must only be assembled and put into operation by qualified personnel.
- The product must only be operated within the specified technical parameters. The technical parameters are described in detail in this documentation.
- The operating and maintenance manual of the specific complete system must also always be observed.

If the product can no longer be operated safely:

1. Remove the product from operation and mark it accordingly
- ✓ It is then not permissible to continue using or operating the product

5.2 Assembly information

The hydraulic power pack must only be installed in the complete system with standard and compliant connection components (screw fittings, hoses, pipes, etc.).

The hydraulic power pack must be shut down correctly prior to dismantling; this applies in particular to power packs with hydraulic accumulators.



Danger

Risk to life caused by sudden movement of the hydraulic drives when dismantled incorrectly!

Risk of serious injury or death.

- Depressurise the hydraulic system.
- Perform safety measures in preparation for maintenance.



Note

The pump unit may only be installed and connected by a qualified specialist who is familiar with and adheres to general engineering principles and relevant applicable regulations and standards.

The electrical connection is to be carried out by a qualified specialist who has received appropriate training.

The following directives and standards must be observed:

- ISO 4413 Hydraulic fluid power – general rules for application
- [D 5488/1](#) Oil recommendations
- [B 5488](#) General operating and maintenance manual

5.2.1 Transport information

Vertical version

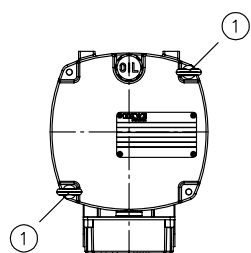
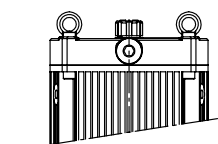

1 Eye-bolt screw-in points

Pump with external fan

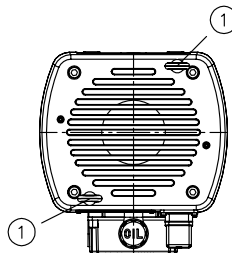
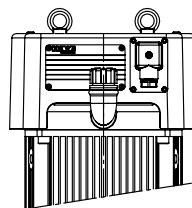

1 Eye-bolt screw-in points

Horizontal version

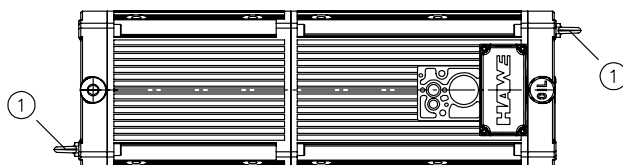
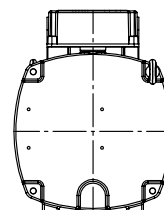
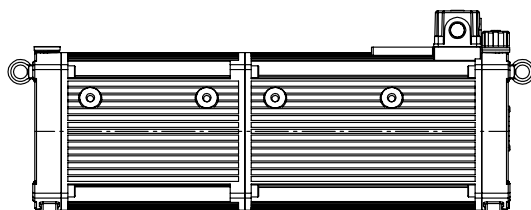
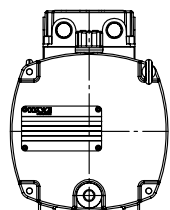

1 Eye-bolt screw-in points

The eye-bolts are contained in the scope of delivery of the KA power pack.

Material number 6016 1203-00

Eye-bolt ISO 3266 M8x13

5.2.2 Identification

See type plate or option table

5.2.3 Setting up and attaching

- Setting up



Danger

Risk of injury due to hot compact hydraulic power pack and hot directional valve solenoids during operation.

Danger of burning.

- Do not touch the compact hydraulic power pack or directional valve solenoids during operation.
- Allow the compact hydraulic power pack and directional valve solenoids to cool down before any work.
- Wear protective gloves.



Note

If surface temperatures >60°C occur during operation, isolating safety devices are to be provided. Ensure that fresh air can be drawn in and that warm air can escape. No changes of any kind (mechanical, welding or soldering work) may be made.

- Installation position in accordance with version, see [Chapter 2.1, "Motor and container"](#), Table 1c
- For dimensions, see [Chapter 4.2, "Basic pump "](#)
- For mounting hole pattern, see [Chapter 4.1, "Mounting hole pattern"](#)
- Recommended attachment

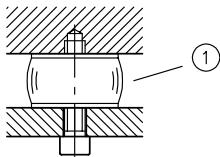

1 Damping element Ø40x30/M8 (65 Shore)

- Weight (for the basic power pack, without valve mounting and oil filling)
For mass (weight) of connection blocks and valve banks, see the corresponding publications

Type	KA 2, KAW 2					
	H (3 cylinders)	H (6 cylinders)	Z	HZ		
KA 21, 23	10.9 kg	11.5 kg	12.7 kg	13.2 kg	Tank size 01, 1	+0.7 kg
KA 22, 24	13.2 kg	13.6 kg	15.0 kg	15.5 kg	Tank size 02, 2	+2.2 kg
KA 26, 28	14.7 kg	15.1 kg	16.5 kg	17.0 kg	Tank size 11	+1.4 kg
					Tank size 21	+2.9 kg
					Tank size 22, 3	+4.4 kg
					External fans F, F1	+2.1 kg
					External fans FSL, FSR, FSH	+0.54 kg (1x110 V, 1x230 V) +0.22 kg (24 V DC)
					External fan FSLR	+1.1 kg (1x110 V, 1x230 V) +0.45 kg (24 V DC)

5.2.4 Electrical connection and selection of the motor protection circuit-breaker

- Connecting the electric drive (see [Chapter 3.2, "Electrical"](#))
- Connecting the float and level gauge (see [Chapter 3.2, "Electrical"](#))



Note

Response temperature in accordance with the built-in temperature switch (see [Chapter 2.1, "Motor and container"](#), Table 1d and [Chapter 3.2, "Electrical"](#)).



Note

If the amount of oil removed during each operating cycle causes the oil level to fall below the monitoring level of the level switch, then suitable electrical measures are to be taken in order to ignore the signal until the oil level rises above the monitoring level once again as a result of the oil flowing back in at the end of the operating cycle.

- Setting the motor protection circuit breaker
 - The motor protection circuit breaker is set to approx. $(0.85 \text{ to } 0.9) I_N$ (see motor current [Chapter 3.2, "Electrical"](#)). This ensures that the motor protection circuit breaker is not triggered prematurely during normal operation, but that the response of the pressure-limiting valve before switch-off is not so long that the max. permissible oil temperature is exceeded.
 - The settings of the motor protection circuit breaker must be checked during the test run. Temperature switches, level switches and pressure switches are further safety measures against malfunctions.

5.2.5 Information on ensuring EMC (electromagnetic compatibility)

If compact hydraulic power packs (induction machine in accordance with EN 60034-1 12.1.2.1) are connected to a system (e.g. power supply unit according to EN 60034-1 para. 6), they do not generate any non-permissible fault signals (EN 60034-1 para. 19). Stability tests for demonstrating compliance with the standard EN 60034-1 para. 12.1.2.1 or VDE 0530-1 are not required. Any brief and potentially disruptive electromagnetic fields generated when switching the motor on and off can be weakened, for example, using suppressor type 23140, 3x400 V AC 4 kW 50-60 Hz, made by Murr-Elektronik, D-71570 Oppenweiler, Germany.

A suppressor can be ordered as an option. ([Chapter 2.1, "Motor and container"](#), Table 1e)

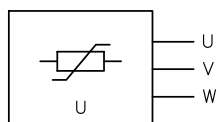

5.3 Operating instructions

Product configuration and setting the pressure and flow rate

The statements and technical parameters in this documentation must be strictly observed.
The instructions for the complete technical system must also always be followed.

Note

- Read the documentation carefully before usage.
- The documentation must be accessible to the operating and maintenance staff at all times.
- Keep documentation up to date after every addition or update.



Caution

Risk of injury on overloading components due to incorrect pressure settings!

Risk of minor injury.

- Always monitor the pressure gauge when setting and changing the pressure.

Purity and filtering of the hydraulic fluid

Fine contamination can significantly impair the function of the hydraulic component. Contamination can cause irreparable damage.

Examples of fine contamination include:

- Metal chips
- Rubber particles from hoses and seals
- Dirt due to assembly and maintenance
- Mechanical debris
- Chemical ageing of the hydraulic fluid

Note

Fresh hydraulic fluid from the drum does not always have the highest degree of purity. Under some circumstances the fresh hydraulic fluid must be filtered before use.

Adhere to the cleanliness level of the hydraulic fluid in order to maintain faultless operation.
(Also see cleanliness level in [Chapter 3, "Parameters"](#)).

Always fill the hydraulic fluid via the system filter or a mobile filter station.

Check for correct connection

- Electrical: power supply, control
- Hydraulic: piping, hoses, cylinders, motors
- Mechanical: attachment to the machine, the frame and the base

Motor protection

- The electric drive must be protected with a motor protection circuit.
For the current setting, see [Chapter 5.2.4, "Electrical connection and selection of the motor protection circuit-breaker"](#)

Fill volume and usable volume

Coding	KA 2, KAW 2		
	Fill volume V_{fill} (l)	Usable volume vertical V_{usable} (l)	Usable volume horizontal V_{usable} (l)
--	3.9	1.85	1.5
1	5.0	2.7	2.0
01	5.0	1.85	2.0
11	6.1	2.7	2.5
2	7.5	5.45	3.15
02	7.5	--	3.15
21	8.6	5.45	3.65
22	11.1	--	4.8
3	11.1	9.05	4.8



Note

- The fill volume and usable volume may deviate slightly from the values indicated here, depending on the motor and pump.

Rotation direction

- Radial piston pump – any
- Gear pump – anticlockwise
- HKF-type – anticlockwise

(Rotation direction is only ascertainable from a check of delivery flow. If there is no delivery flow in the three-phase version, replace two of the three main conductors.)

Start and bleeding

- Directional valve is in switching position in which the depressurised circulation of the pump is possible.
 1. Switch the pump on and off several times so that the pump cylinders bleed automatically.
- If the controller is not designed for this,
 2. a pipe screw connection with a short pipe bracket and a transparent plastic tube can be attached to connection P.
 3. Insert the other end into the opening for the oil filler (unscrew the air filter).
- ✓ When the oil flow is free of bubbles, the pump has been bled.
- 4. Then move the consumer(s) back and forth several times until the air is largely removed there too and the movement is smooth.
- 5. If the consumers have bleed points, loosen the locking elements and only tighten them once bubble-free oil emerges.

Directional valves

- Any solenoid valves must be connected to the controller in accordance with the hydraulic schematic and function diagram.

Accumulator systems

- Accumulators should be filled using designated equipment in accordance with the pressure specifications of the hydraulic schematic. The relevant operating and maintenance manuals must be followed.



Caution

Risk of injury due to incorrect transportation.

Risk of minor injury.

- Comply with the regulations on transportation and safety.
- Wear protective equipment.

Silica gel filter

- When using a silica gel filter, remove the red caps on the underside of the compact hydraulic power pack prior to commissioning.

5.4 Maintenance information

This product is largely maintenance-free.

Conduct a visual inspection at regular intervals, but at least once per year, to check if the hydraulic connections are damaged. If external leakages are found, shut down and repair the system.

Clean the device surface of dust deposits and dirt at regular intervals, but at least once per year.

Ensure that the oil level is checked regularly.

The oil must be changed once a year; any pressure or return line filters must be changed.

For further information, see [B 5488](#)!

When using a silica gel filter,

- inspect every six months
- dispose of used filter materials in the bin for equipment stained with oil (ÖvB)

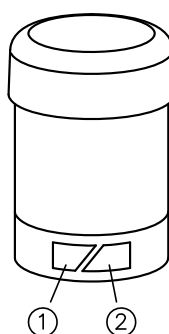

- 1 orange
- 2 red

Silica gel filter

- red = OK
- orange = needs to be changed



Note

Before starting maintenance or repair work:

- Depressurise the system on the fluid side. This applies in particular for systems with hydraulic accumulators.
- Switch off or interrupt the power supply.

Repairs and spare parts

- Repairs (replacement of wearing parts) can be carried out by trained specialists themselves. A spare parts list is available on request. The electric drive cannot be replaced.

5.5 Disposal information

- Valve control
 - Mixed scrap
- Pump housing with motor
 - Electronic waste
- Tank or hydraulic accumulator, as applicable (depressurised on the gas side)
 - Scrap iron
- Hydraulic fluid
 - Waste oil

6 Other information

6.1 Planning information

6.1.1 Selection advice

The procedure for the selection and design of compact hydraulic power packs with a valve attachment is described below. In order to find the ideal solution, several iterative steps generally have to be carried out.

a) Setting up a function diagram

The required or desired (hydraulically activated) functions form the basis for the function diagram.

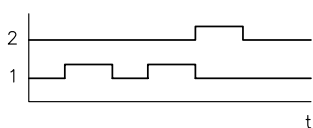

b) Definition of pressures and flow rates

- Dimensioning and selection of actuators on the basis of the reaction forces arising
- Calculation of the individual flow rates on the basis of the required velocity profiles



Note

Take note of the reset times for spring-loaded clamping cylinders.

In the case of time-linked clamping devices, the release of spring-loaded clamping cylinders may often have a greater influence over the time interval than clamping. The return stroke times are determined exclusively by the forces of the reset springs. They drive the cylinder pistons ahead, against the flow resistance from directional valves and pipelines. This must be noted in the dimensions of pipelines or hose lines, as well as valves.

- Calculation of the individual operation pressures required
- Determination of the maximum (pump) delivery flow required – Q (lpm)
- Determination of the (system) operating pressure – p_{\max} (bar)

Q - flow rate

p - pressure

A - Area

v - Velocity

F - Force

$$Q \left(\frac{l}{\text{min}} \right) = 0.06 \cdot A \left(\text{mm}^2 \right) \cdot v \left(\frac{\text{m}}{\text{s}} \right)$$

$$p \left(\text{bar} \right) = \frac{10 \cdot F \left(\text{N} \right)}{A \left(\text{mm}^2 \right)}$$

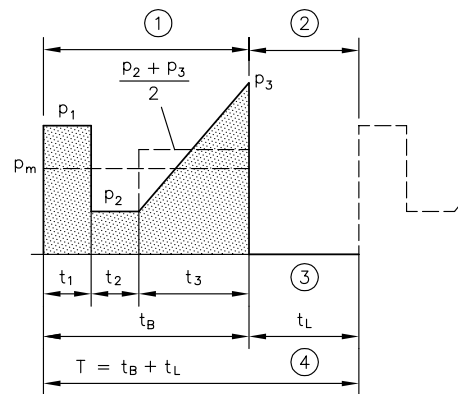

- 1 Load time
- 2 No-load time
- 3 No load
- 4 One working cycle

c) Preparation of the hydraulic schematic

- Criteria:
 - single circuit system
 - Accumulator charging mode
 - Dual-circuit systems with two separately operating hydraulics circuits
 - Dual-circuit systems with a shared hydraulics circuit (for instance, in presses or hydraulic tools as high-pressure systems / low-pressure systems, in handling systems with velocity control/rapid feed/creep)
 - Use of an accumulator for the short-term support of the pump delivery flow

d) Setting up a time/load diagram on the basis of a function diagram

- Deriving the mode for the compact hydraulic power pack
 - Calculation of the relative ON-time %ED
 - S1 – continuous operation (not suitable for compact hydraulic power packs)
 - S2 – short period operation
 - S3 – standby mode
 - S6 – continuous run with intermittent load (only suitable in combination with fans with coding F)

e) Selection of a compact hydraulic power pack

- Definition of the basic type on the basis of the power supply
 - Three-phase current – KA-type
 - Alternating current – KAW-type
- Motor selection
 - Voltage tolerances: $\pm 10\%$ (IEC 38), at 3x460/265 V 60 Hz $\pm 5\%$
 - A three-phase motor 400 V 50 Hz can be used without restrictions in 460 V 60 Hz supply networks. Alternating current motors can only be used in supply networks at the nominal voltage and nominal frequency.
 - It can be operated at undervoltage. Bear in mind that this will involve performance restrictions.

$$p_{\max \text{ red}} = p_{\max} * k$$

p_{\max} (bar) – max. operating pressure in accordance with the selection tables

$p_{\max \text{ red}}$ (bar) – reduced max. available operating pressure

* k – correction factor from the diagram

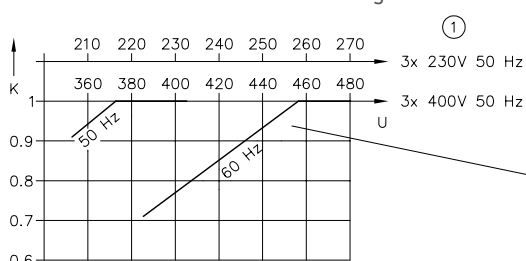

U supply voltage (V); K correction factor

1 Motor design



Note

Pump delivery flow 1.2 x greater than at 50 Hz operation!

- Selection of the pump type (radial piston pump, gear pump pump combination)
- Selection of the key figure for the pump delivery flow with due regard for the maximum permissible pressure and definition of the basic type with the motor size
- Estimation of the noise level from the diagrams in [Chapter 3, "Parameters"](#)

f) Calculation of the hydraulic work value

- Calculation of the average pressure
- Calculation of the average hydraulic work value (average pressure x output volume)
- Calculation of the maximum hydraulic work value (maximum operating pressure x output volume)

p_m (bar) = calculated average pressure per cycle during the load time

$$t_B = t_1 + t_2 + t_3 + \dots$$

$$p_m = \frac{1}{t_B} \left(p_1 \cdot t_1 + p_2 \cdot t_2 + \frac{p_2 + p_3}{2} \cdot t_3 + \dots \right)$$

$p_m V_g$ = average hydraulic work value

V_g = geometric displacement volume in accordance with the tables [Chapter 2.2, "Pump"](#)

$$p V_{g \text{ max}} (\text{bar cm}^3) = p_{\max} * V_g$$

g) Determination of excess temperature**Caution**

Take note of the max. permissible oil temperature of 80°C!

The steady-state temperature is reached after an operating time of about half an hour.

Influencing variables:

- Pressure run during the load phase (average pressure)
- Time share of the no-load phase
- Additional throttle losses over and above normal flow resistances (approx. 30%) from valves and lines are only to be taken into account if they take effect over a longer share of time within a working cycle (load phase). For instance, this includes work against the pressure-limiting valve (loss = 100%)

In order to conduct an approximate check on the steady-state temperature of the oil fill, you generally only require the two most important items of data, i.e. average hydraulic work of the pump ($p_m V_g$) and relative load duration per working cycle (%ED).

- In the case of a tank size with coding 02, 2, 22, 3, the steady-state temperature is approximately 15% lower.
- Additional fan:
 - Additional fan coding F or F1
Reduction in the steady-state temperature by approx. 50%
 - Side fan coding FSL, FSR, FSH
Reduction in the steady-state temperature by approx. 55%
 - 2 side fans coding FSLR
Reduction in the steady-state temperature by approx. 60%
- The steady-state temperature which can actually be reached also depends on the switch-on mode of the fan:
 - only switched on if the pump is working
 - runs on (temperature-controlled and/or time-controlled)
 - runs continuously

$$\vartheta_{oil\ u} = \Delta\vartheta_B + \vartheta_U$$

$\Delta\vartheta_B$ (K) - Steady-state temperature, assessment from the diagrams opposite

ϑ_U (K) - Ambient temperature at the place of installation

$\vartheta_{oil\ u}$ (°C) - Steady-state temperature of the oil fill

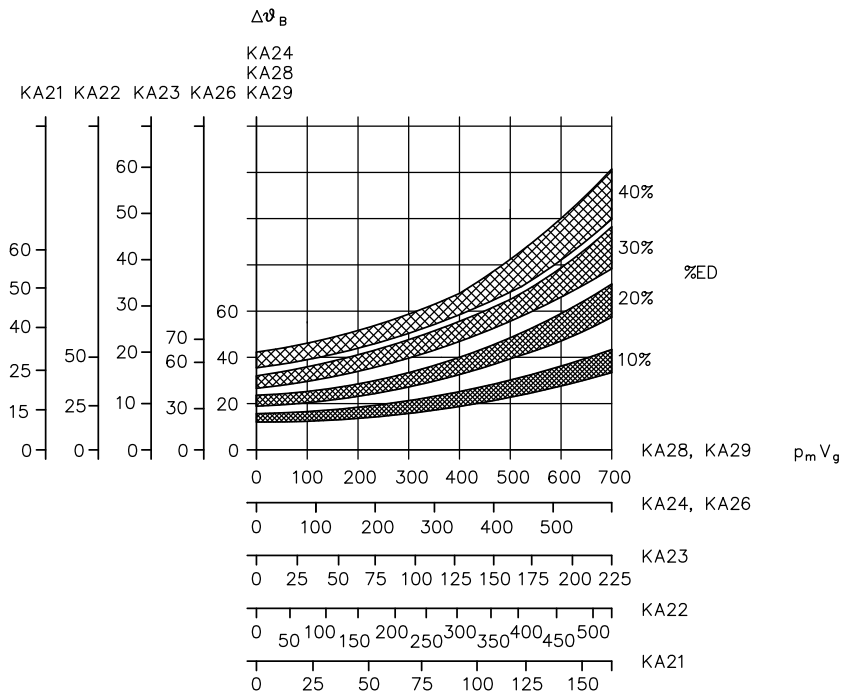

$p_m V_g$ average hydraulic work value (bar cm^3); $\Delta\vartheta_B$ expected steady-state temperatures (K); %ED relative ON-time

$$\text{Relative duty cycle \% ED} = \frac{t_B}{t_B + t_L} \cdot 100$$



Note

Lower steady-state temperatures are possible with a fan (coding F) and/or larger tank (see above).

h) Determination of the max. current consumption

See diagrams [Chapter 3.2, "Electrical"](#)

for the settings of the motor protection circuit breaker, see [Chapter 5.2.4, "Electrical connection and selection of the motor protection circuit-breaker"](#)

i) Selection of the operating capacitor for type KAW

An operating capacitor is required in order to operate a single-phase-motor. The values indicated in [Chapter 3.2, "Electrical"](#), Table 5 ensure that the pressures indicated in the selection tables are achieved.

When using <75% of the maximum capacity of the hydraulic work value (pV_g), a capacitor which is approximately 30% smaller is to be used to reduce power losses.



Note

The operating capacitor is not included in the scope of delivery.

Capacitor selection

Motor voltage	Rated voltage
1x230 V 50 Hz 1x220 V 60 Hz	400 V DB
1x110 V 60 Hz 1x115 V 50 Hz	230 V DB

j) After-run

If the compact hydraulic power pack is wired directly to the hydraulic cylinder, e.g. in the circuit for clamping devices (B-type connection blocks), and if a pressure switch causes it to cut out once the set pressure has been reached, a certain increase in pressure still takes place as a result of the after-run action of the pump motor. The level of this additional rise in pressure is dependent on the pressure setting, on the consumer volume and on the pump delivery flow. If you wish to prevent these pressure rises, the setting for the pressure-limiting valve has to be adjusted in line with the switch-off point on the pressure switch. As a result, the subsequent delivery from the pump is discharged via the pressure-limiting valve.

The adjustment is to be carried out as follows:

- 1 Open the pressure-limiting valve fully.
- 2 Set the pressure switch to the highest value (by turning the setting screw clockwise as far as it will go).
- 3 Switch on the pump (with a consumer and pressure gauge connected) and turn up the pressure-limiting valve until the pressure gauge shows the required end operating pressure.
- 4 Turn the pressure switch in the opposite direction until the pump is switched off at the pressure setting (see [Chapter 3, "Parameters"](#)).
- 5 Locking the pressure-limiting valve and the pressure switch.

The rise in pressure due to the after-run can also be avoided by using an accumulator or additional volume in the consumer line. If the compact hydraulic power pack is used to full capacity, i.e. the pressure setting is close to the maximum permissible pressure according to the selection tables in [Chapter 2.1, "Motor and container"](#) and [Chapter 2.2, "Pump"](#), practically no after-run occurs because the pump comes to a stop almost as soon as it is switched off.

k) Silica gel filter

It makes sense to use a silica gel filter in cases where there is a possibility of water (condensation) escaping into the tank (risk of short circuit!) via the breather filter due to temperature fluctuations and/or high relative humidity.



Note

Take note of the maintenance information in [Chapter 5.4, "Maintenance information"](#)!

h) Connection block and valve mounting

A connection block is necessary to make a compact hydraulic power pack ready for a hydraulic connection.

Type	Description	Publication
A, AL, AM, AK, AS, AV, AP	For single-circuit pumps with a pressure-limiting valve and the possibility of direct mounting of directional valve banks Optional: <ul style="list-style-type: none"> – Pressure filter or return line filter – Idle circulation valve – Accumulator charging valve – Proportional pressure-limiting valve 	D 6905 A/1
AN, AL, NA, C30, SS, VV	For dual-circuit pumps with a pressure-limiting valve and the partial possibility of direct mounting of directional valve banks Optional: <ul style="list-style-type: none"> – Pressure filter or return line filter – Accumulator charging valve – Two-stage valve – Idle circulation valve 	D 6905 A/1
AX	For single-circuit pumps with a pressure-limiting valve with unit approval and the possibility of direct mounting of directional valve banks (for use in accumulator systems) Optional: <ul style="list-style-type: none"> – Pressure filter or return line filter – Idle circulation valve 	D 6905 TÜV
B	For single-circuit pumps for the activation of single-acting cylinders with a pressure-limiting valve and drain valve Optional: <ul style="list-style-type: none"> – Throttle valve 	D 6905 B
C	For single-circuit pumps with connections P and R for direct piping	D 6905 C



Note

When setting the pressure-limiting valve on the connection block, take note of the maximum permissible pressure of the pump!

The direct mounting of valve banks with directional valves on A-type connection blocks enables a compact hydraulic unit to be assembled without the need for additional piping.

Type	Description	p _{max} (bar)	Publication
VB	Valve bank (directional seated valve)	700	D 7302
BWN, BWH	Valve bank (directional seated valve)	450	D 7470 B/1
SWR, SWS	Valve bank (directional spool valve)	315	D 7451 , D 7951
BA	Valve bank for the combination of different directional valves with connection pattern NG 6 in accordance with DIN 24 340-A6	400	D 7788
BVH	Valve bank (directional seated valve)	400	D 7788 BV
NBVP	Directional seated valve	400	D 7765 N
NSWP	Directional spool valve	315	D 7451 N
NSMD	Clamping module (Directional spool valve with a pressure reducing valve and acknowledge function)	315	D 7787
NZP	Intermediate plates with connection pattern NG 6 in accordance with DIN 24 340-A6	400	D 7788 Z

6.2 Explanations

HAWE Hydraulik SE
 info@hawe.de
 www.hawe.com



Steffelsstraße 25
 D-81673 München
 Tel. +49 89 370100-0
 Fax +49 89 370100-1289

HAWE Hydraulik SE, Postfach 80 09 04, D-81608 München

Datum
 2017-11-03

E-Mail

Telefon

Ihr Ansprechpartner

Declaration of Incorporation within the meaning of the Machinery Directive 2006/42/EC, appendix II, No.1 B

Compact hydraulic power pack type KA, KAW, KA2.../ZM... and KAW2.../ZM... according to our documentation D 8010, D 8010-4, SK 8010 L1, SK 8010 S1 and SK 8010 W (latest release) is an incomplete machine (acc. to article 2g), which is exclusively intended for installation or assembly of another machinery or equipment.

The specific technical documents, necessary acc. to appendix VII B, can be prepared any time and transmitted in electronic form to the responsible national authority on request. Risk assessment and analysis are implemented according to appendix I of the Machinery Directive. The dept. MARKETING is authorized to compile the specific technical documents necessary acc. to appendix VII B.

HAWE Hydraulik SE, Dept. Marketing, Steffelsstraße 25, D-81673 München

The following basic safety and health protection requests acc. to appendix 1 of this guideline do apply and are complied with:

Chapter 1.1.2, 1.1.3, 1.1.5, 1.2 (complete chapter), 1.3.1, 1.3.2, 1.3.4, 1.3.6, 1.3.7, 1.5.1, 1.5.2, 1.5.3, 1.5.4, 1.5.4, 1.5.5, 1.5.6, 1.5.8, 1.5.9, 1.5.16, 1.6.3, 1.7.1, 1.7.3, 1.7.4 and 1.7.4.3.

The incomplete machine also fulfills below shown EU-Directives:
 2014/35/EU/2014-02-26 Directive of electrical equipment designed for use within certain voltage limits
 2014/68/EU/2014-05-15 Pressure equipment Directive (applicable if an accumulator is used)

Following harmonised guidelines have been used:
 EN 12004-1:2011-03 Safety - General principles for design
 EN ISO 4413:2011-04 Hydraulic fluid power - General rules and safety requirements for systems and their components
 EN ISO 4413:2011-04 Safety of machinery - Electrical equipment of machines - Part 1: General requirements

We assume that the delivered equipment is intended for the installation into a machine. Putting in operation is forbidden until it has been verified that the machine, where our products shall be installed, is complying with the Machinery Directive 2006/42/EC. This Declaration of Incorporation is void, when our product has been modified without our written approval.

I.A. Dipl.-Ing. A. Nocker (Technical Support Marketing)
 Zertifiziert nach
 ISO 9001
 ISO 14001
 ISO 50001
 Europäische Aktiengesellschaft (SE), Sitz der Gesellschaft, München, USt-ID Nr.: DE80016198, Registergericht München HRB 174780
 Vorstand: Karl Heesgen/Martin Heuser, Wolfgang Schor, Markus Ulmerstein
 Vorsitzender des Aufsichtsrats Hans-Jürgen Thaus, Ehrenvorsitzender des Aufsichtsrats Joachim Gemlich
 Geschäftsführer: I.A. Dipl.-Ing. A. Nocker
 Commerzbank München: 150523700 (BLZ 700 400 411, IBAN DE88 7004 004 01 050 6237 00, BIC COBADE33XXX
 Baden-Württembergische Bank: 2386049 (BLZ 260 501 01), IBAN DE88 6005 010 002 3800 48, BIC SOLADE33
 Bayerische Landesbank: 203693428 (BLZ 700 500 001), IBAN DE88 7005 0000 0203 6934 28, BIC BYLADE33XXX

00 6026 866

HAWE Hydraulik SE
 info@hawe.de
 www.hawe.com



Steffelsstraße 25
 D-81673 München
 Tel. +49 89 370100-0
 Fax +49 89 370100-1289

HAWE Hydraulik SE, Postfach 80 09 04, D-81608 München, Germany

Datum
 2015-07-01

Declaration of conformity within the meaning of European Directive 2014/35/EC electrical equipment designed for use within certain voltage limits

We, HAWE Hydraulik SE, headquartered at D-81673 München, Steffelsstraße 25 take sole responsibility for the following declaration that the product

Compact hydraulic power pack types KA, KAW, KA2.../ZM... and KAW2.../ZM... according to our publication D 8010, D 8010-4 SK8010L1, SK8010S1 and SK8010W (the current issue of each respective publication)

to which this declaration refers, complies with the following standards or normative documents

DIN EN 60034 (DIN VDE 0530)
 DIN VDE 0110

If a change is made to the product that has not been agreed in writing with the manufacturer, this declaration shall become void

HAWE Hydraulik SE

I.A. Dipl.-Ing. A. Nocker (Risk management)

Europäische Aktiengesellschaft (SE), Sitz der Gesellschaft, München, USt-ID Nr.: DE80016198, Registergericht München HRB 174780
 Vorstand: Karl Heesgen/Martin Heuser, Wolfgang Schor, Markus Ulmerstein
 Vorsitzender des Aufsichtsrats Hans-Jürgen Thaus, Ehrenvorsitzender des Aufsichtsrats Joachim Gemlich
 Geschäftsführer: I.A. Dipl.-Ing. A. Nocker
 Commerzbank München: 150523700 (BLZ 700 400 411, IBAN DE88 7004 004 01 050 6237 00, BIC COBADE33XXX
 Baden-Württembergische Bank: 2386049 (BLZ 260 501 01), IBAN DE88 6005 010 002 3800 48, BIC SOLADE33
 Bayerische Landesbank: 203693428 (BLZ 700 500 001), IBAN DE88 7005 0000 0203 6934 28, BIC BYLADE33XXX

00 6026 866

Further information

Additional versions

- Compact hydraulic power packs type KA and KAW size 4: D 8010-4
- Compact hydraulic power pack type MPN and MPNW: D 7207
- Compact hydraulic power pack type HK 2: D 7600-2
- Compact hydraulic power pack type HK 3: D 7600-3
- Compact hydraulic power pack type HKL and HKLW: D 7600-3L
- Compact hydraulic power pack type HK 4: D 7600-4
- Compact hydraulic power pack type HC and HCW: D 7900
- Compact hydraulic power pack type NPC: D 7940
- Connection blocks type A for hydraulic power packs: D 6905 A/1
- Connection block type AX, with unit approval: D 6905 TUV
- Connection blocks type B for hydraulic power packs: D 6905 B
- Connection block type C 5 and C 6: D 6905 C
- Valve bank (directional seated valve) type VB: D 7302
- Valve bank (directional seated valve) type BWN and BWH: D 7470 B/1
- Directional spool valve type SW: D 7451
- Directional spool valve bank type SWS: D 7951
- Valve bank (nominal size 6) type BA: D 7788
- Valve bank (directional seated valve) type BVH: D 7788 BV
- Directional seated valve type NBVP 16: D 7765 N
- Directional spool valve type NSWP 2: D 7451 N
- Clamping module type NSMD: D 7787
- Intermediate plate type NZP: D 7788 Z
- Fitting type X 84: D 7077
- Diaphragm accumulator type AC: D 7969
- Miniature hydraulic accumulators, type AC: D 7571